

CATRIKE

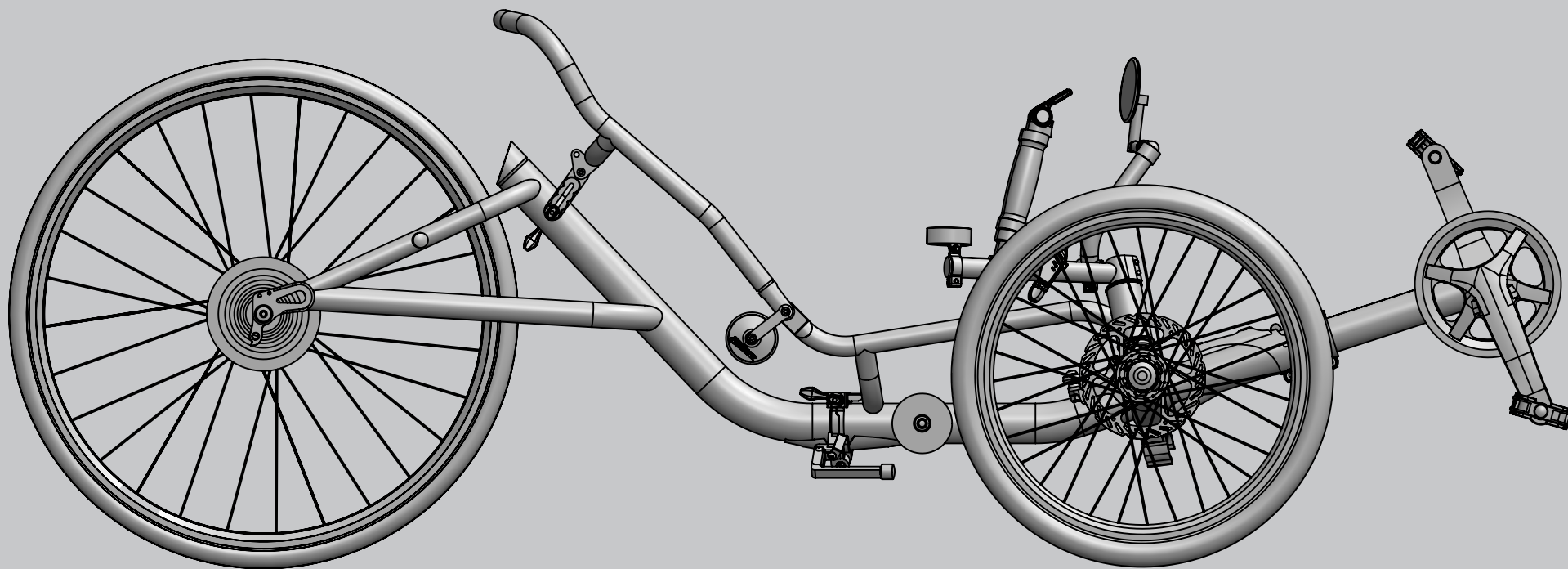

559

TECHNICAL MANUAL

SAFETY INFORMATION



**IMPORTANT:
PLEASE READ BEFORE RIDING**

PRE-RIDE CHECK

- Frame and spindles for any cracks or damage
- Tires for proper inflation and wear
- Brakes and shifting for functionality
- Boom for tightness
- Check for anything that may have worked its way loose like handlebars, adjustable seat bracket, swing arm, suspended spindles or wheels

CATRIKE SAFETY

- Make sure your boom is adjusted to your leg length by a Catrike dealer
- All Catrikes are standard equipped with SPD Style Clipless pedals. **We strongly recommend using clipless shoes for Catrike's SPD pedals to attach your feet securely to the pedals.** If you are uncomfortable with clipless pedals, we recommend a pedal with heel support and straps that hold the foot securely to the pedals. Your Catrike dealer can help you with alternative options. **IMPORTANT: DUE TO THE FORWARD PLACEMENT OF THE CRANKSET, IF YOUR FEET ARE NOT SECURED TO THE PEDALS, THEY COULD SLIP OFF PEDALS AND YOUR LEG CAN BE PULLED UNDER THE FRAME CAUSING SERIOUS INJURY.**
- All Catrikes come standard with safety flags that extend upwards above rider height to be visible to motorists, cyclist and pedestrians. Front and rear lights are also recommended. Always be visible!
- All Catrikes come with a rear-view mirror. This is a useful tool to increase awareness of your surroundings.
- **Always ride under control.** Use a safe speed for your ability when negotiating corners and going down hills. Your trike can tip over if turned too sharply for a given speed. When possible lean into your turns. Never lean the opposite way of turning.
- Catrikes have two brakes - one on the right front wheel and one on the left

front wheel. The brake lever actuates each brake on the corresponding side. For smooth, controlled and safe braking, apply equal force to each lever. Just like on a bicycle, if you squeeze the brake levers in a panic situation, it can cause your front wheels to lock up and pitch you forward. Please take a moment to practice braking to better understand how your Catrike will perform in different stopping conditions.

- Catrike model 700 (only) parking brake safety. After coming to a complete stop pull the microSHIFT parking lever toward you to engage the brake. Before pedaling again release the parking brake by pushing the lever all the way forward. Important: The microSHIFT parking brake actuator on the Catrike 700 should not be engaged while the Catrike is in motion. This is a parking brake only and is not intended to be used to slow or stop the 700. Using the parking brake to slow or stop the 700 could result in loss of control of the trike leading to injury.

GENERAL RIDING SAFETY TIPS

- Obey all rules of the road and all local traffic laws.
- You are sharing the road or the path with others: motorists, pedestrians, and cyclists, respect their rights and interact in a safer manner.
- Ride defensively. Always assume that others do not see you.
- Look ahead and stay alert to be ready to avoid accidents.
- Ride in designated bike lanes or on designated bike paths in the direction of traffic flow or as directed by local signage.
- Stop at stop signs and traffic lights; slow down and look both ways at street intersections. Be prepared to yield even if you have the right of way.
- Use approved hand signals for turning and stopping.
- Never ride with headphones. They mask traffic sounds and emergency vehicle sirens and distract you from concentrating on what's going on around you.
- Do not weave through traffic or make any moves that may surprise others.
- Never ride your Catrike while under the influence of alcohol or drugs.
- Always wear a properly fitted cycling helmet.
- Always ride safely and be aware of your surroundings.

SAFETY INFORMATION: ELECTRIC SYSTEM



IMPORTANT:

PLEASE READ BEFORE RIDING

CATRIKE ELECTRIC ASSIST MODELS

- We recommend electric assist eCatrike users should be **16 and older** or have extensive training and adult supervision.
- Always disconnect the Bosch harness before folding the eCat Dumont, 5.5.9. or Trail. Folding a Catrike while the harness is connected can cause damage to the battery connection and harness.

BATTERY SAFETY

- Be sure to review the original Bosch operating instructions for charger and rechargeable battery.
- Keep the instructions. Make the instructions available to any other user.
- Do not ship a rechargeable battery, as rechargeable batteries must be handled separately as hazardous goods.
- Do not open, damage or repair the charger or the rechargeable battery.
- Protect charger and battery from heat and strong sunlight.

CHARGING SAFETY

- Only use intact charger and rechargeable batteries.
- Only use the specified charger for charging.
- Choose an indoor location that is ventilated, dry, dust-free, and has a smoke detector.
- Place the charger and the rechargeable battery on a fireproof surface when charging.
- The charger, rechargeable battery and plug must not be in a damp or wet state.
- Also check the contacts of the rechargeable battery. Moisture must not be allowed to condense on the rechargeable battery.
- Do not cover charger and rechargeable battery with textiles or flammable material.
- Do not leave a charging battery unattended for an extended period of time.

HEADSET ASSEMBLY.....	4
SPINDLES.....	5-6
TIE ROD.....	7
FRONT WHEEL INSTALL.....	8-11
REAR WHEEL INSTALL.....	12
TIE ROD ADJUSTMENT.....	13-14
HANDLEBARS.....	15-16
BOOM ADJUSTMENT.....	17-18
CABLE ROUTING.....	19
CHAIN ROUTING.....	20
ADJUSTABLE SEATBACK.....	21-23
HINGE ASSEMBLY.....	24-27
ECAT.....	28-38
REAR FENDER ASSEMBLY.....	39-41

HEADSET ASSEMBLY

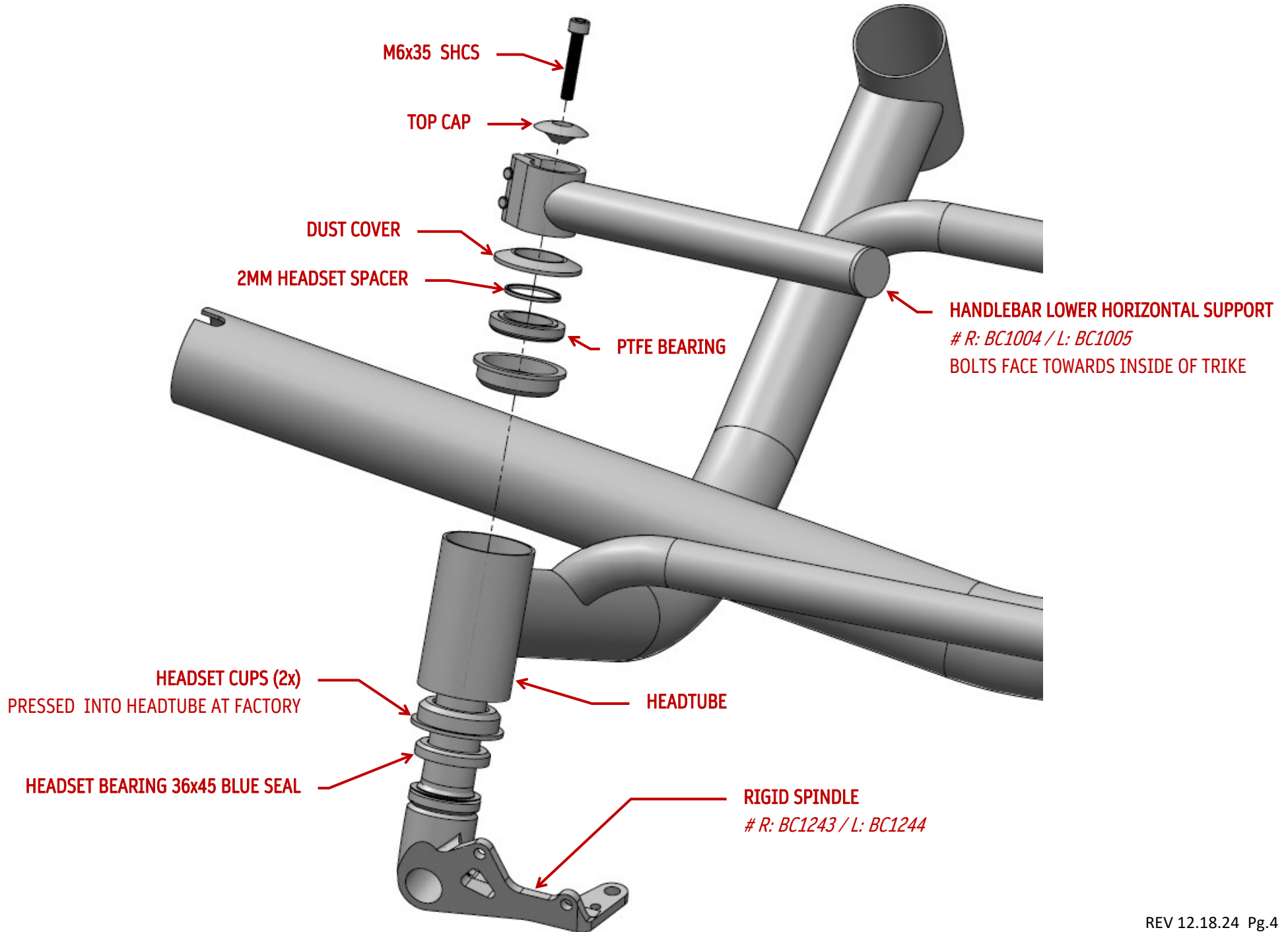

RIGID SPINDLE MAIN ASSEMBLY LEFT

FOR BRAKE AND CALIPER
ADJUSTMENT VISIT
SRAM SERVICE HUB



SRAM BB7 FRONT BRAKES
20MM IS MOUNT FOR 160MM ROTOR
TORQUE BOLTS TO 10Nm (88IN·LBS)

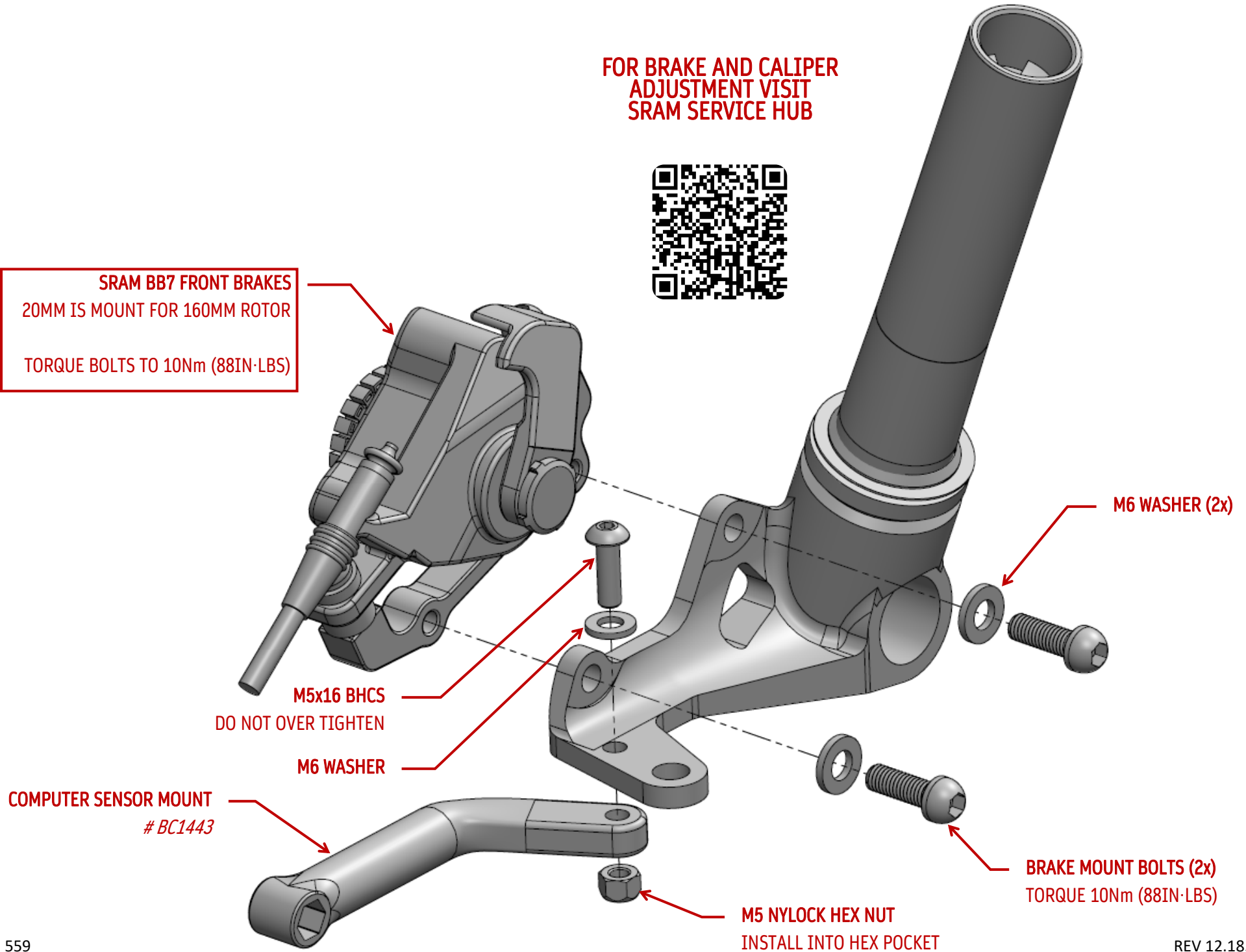

M5x16 BHCS
DO NOT OVER TIGHTEN

M6 WASHER

COMPUTER SENSOR MOUNT
BC1443

M5 NYLOCK HEX NUT
INSTALL INTO HEX POCKET

M6 WASHER (2x)

BRAKE MOUNT BOLTS (2x)
TORQUE 10Nm (88IN·LBS)

RIGID SPINDLE MAIN ASSEMBLY RIGHT

FOR BRAKE AND CALIPER
ADJUSTMENT VISIT
SRAM SERVICE HUB



SRAM BB7 FRONT BRAKES
20MM IS MOUNT FOR 160MM ROTOR
TORQUE BOLTS TO 10Nm (88IN·LBS)

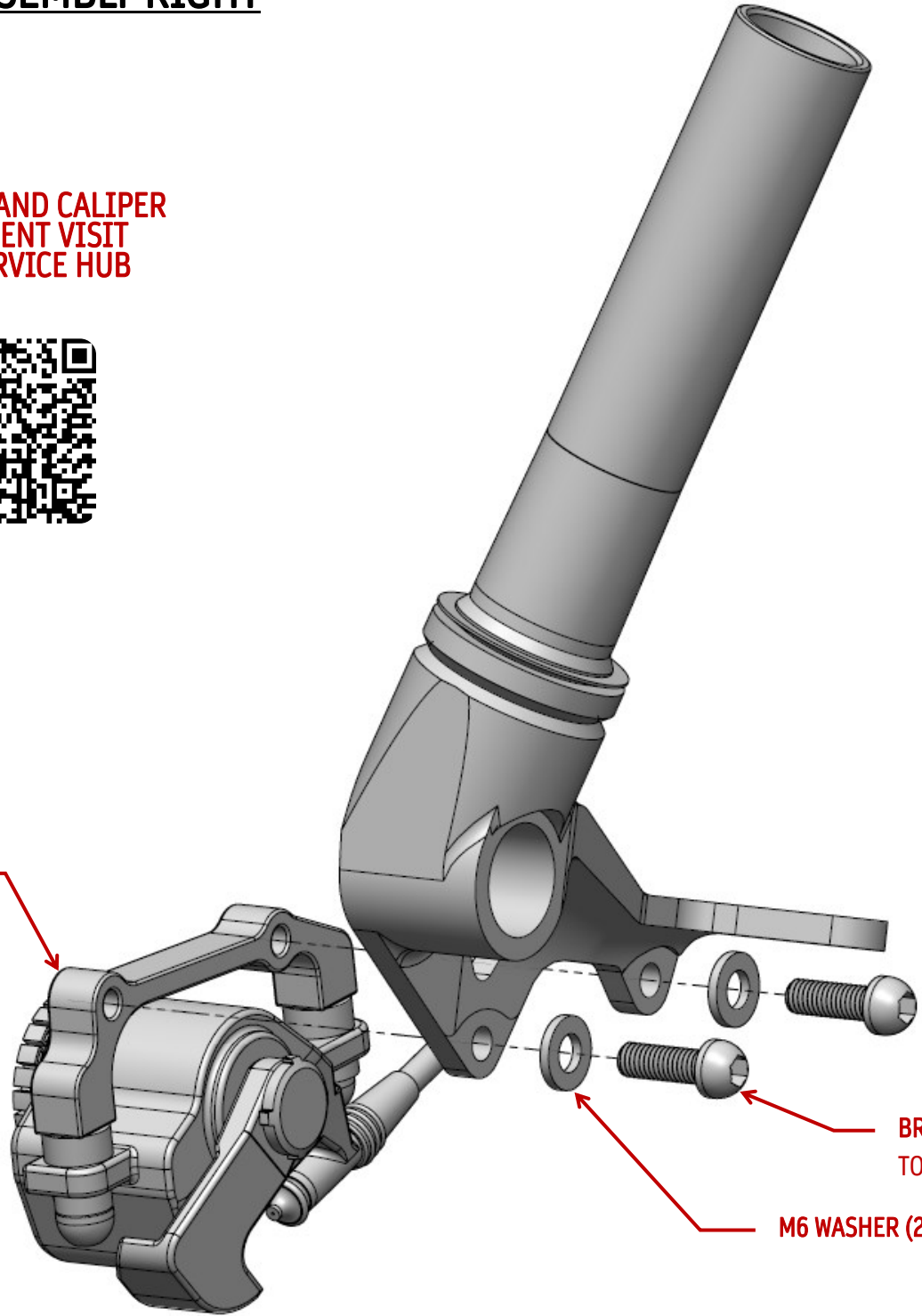

BRAKE MOUNT BOLTS (2x)
TORQUE 10Nm (88IN·LBS)

M6 WASHER (2x)

TIE-ROD ASSEMBLY

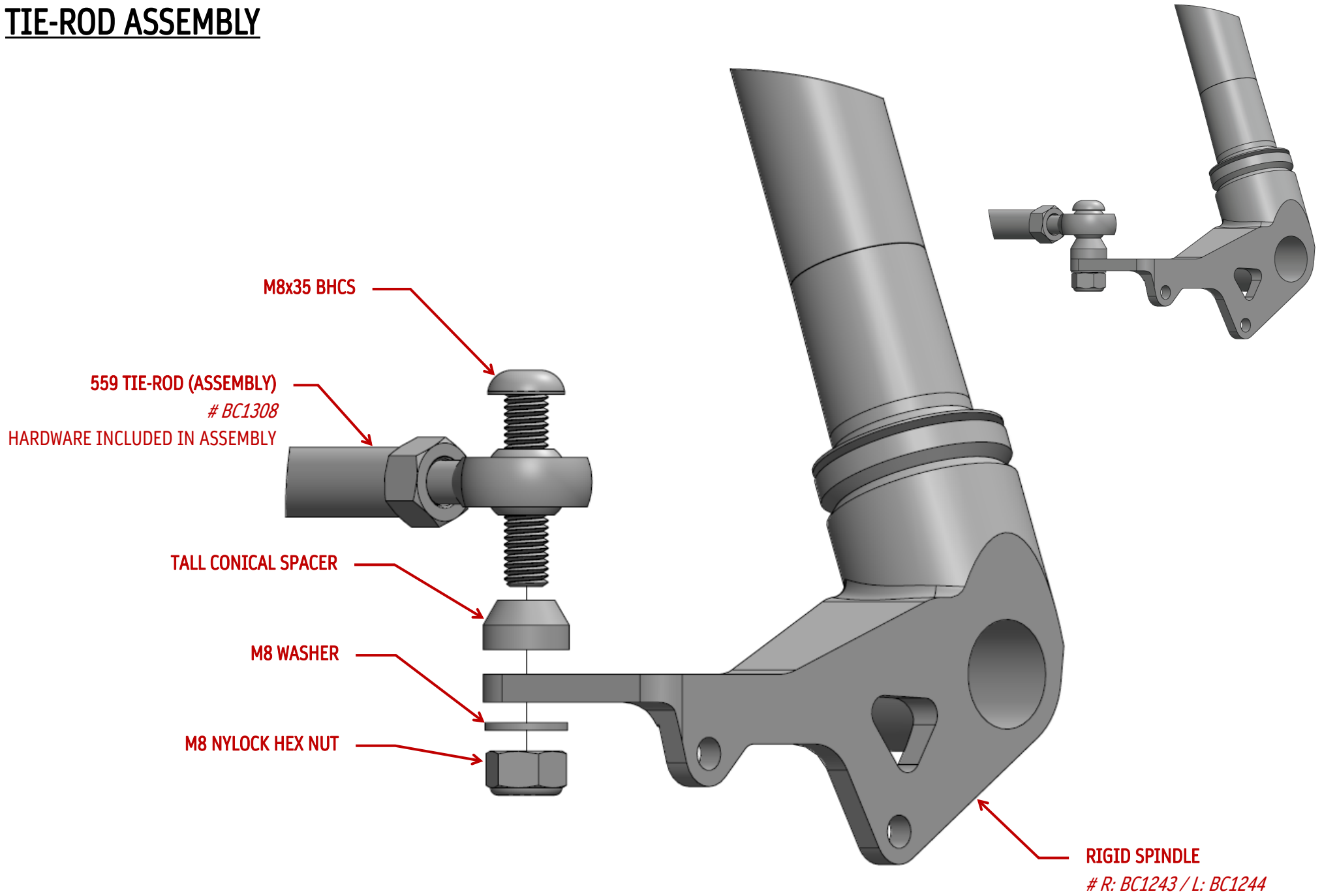

WHEEL INSTALL STEP 1

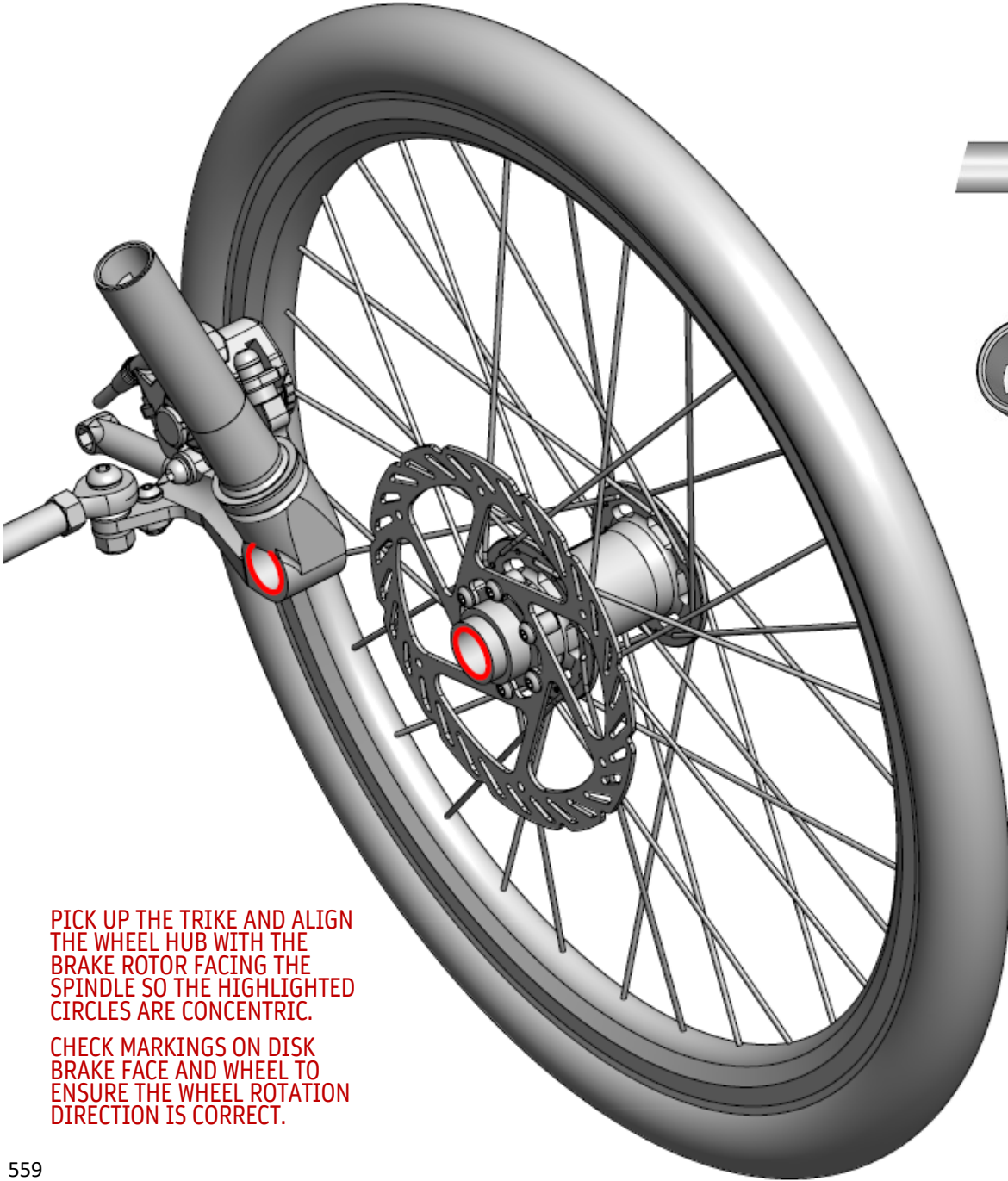

PICK UP THE TRIKE AND ALIGN THE WHEEL HUB WITH THE BRAKE ROTOR FACING THE SPINDLE SO THE HIGHLIGHTED CIRCLES ARE CONCENTRIC.

CHECK MARKINGS ON DISK BRAKE FACE AND WHEEL TO ENSURE THE WHEEL ROTATION DIRECTION IS CORRECT.

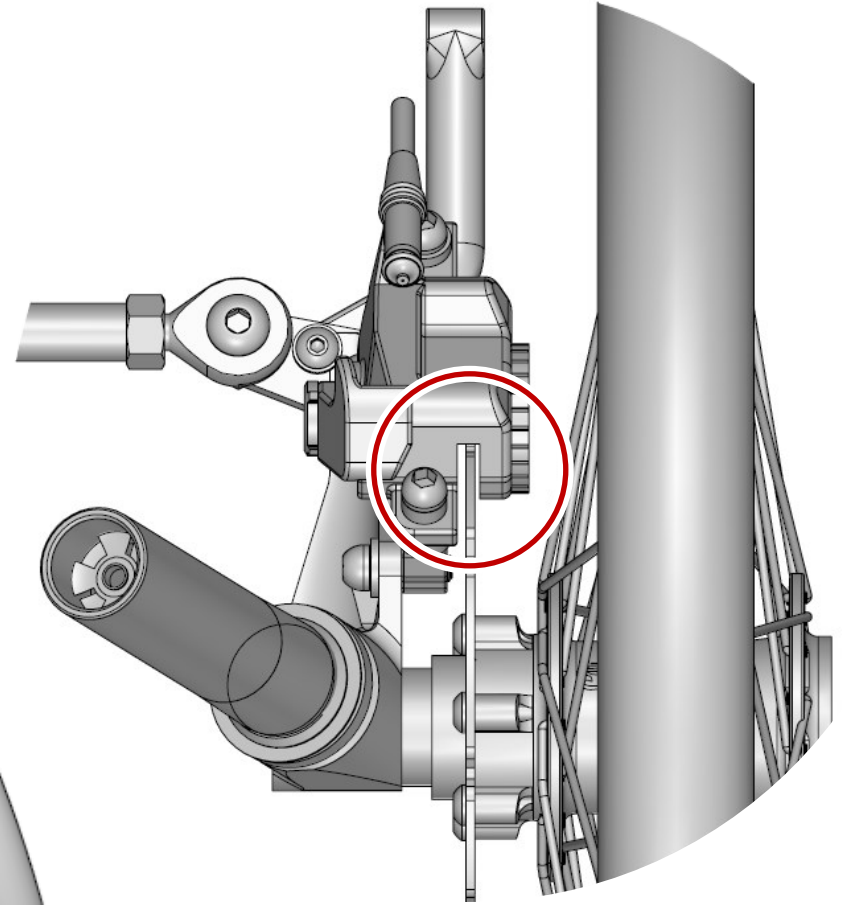

MAKE SURE THAT THE BRAKE ROTOR GOES IN THE CALIPER OPENING WHEN INSTALLING THE WHEEL.

WHEEL INSTALL STEP 2

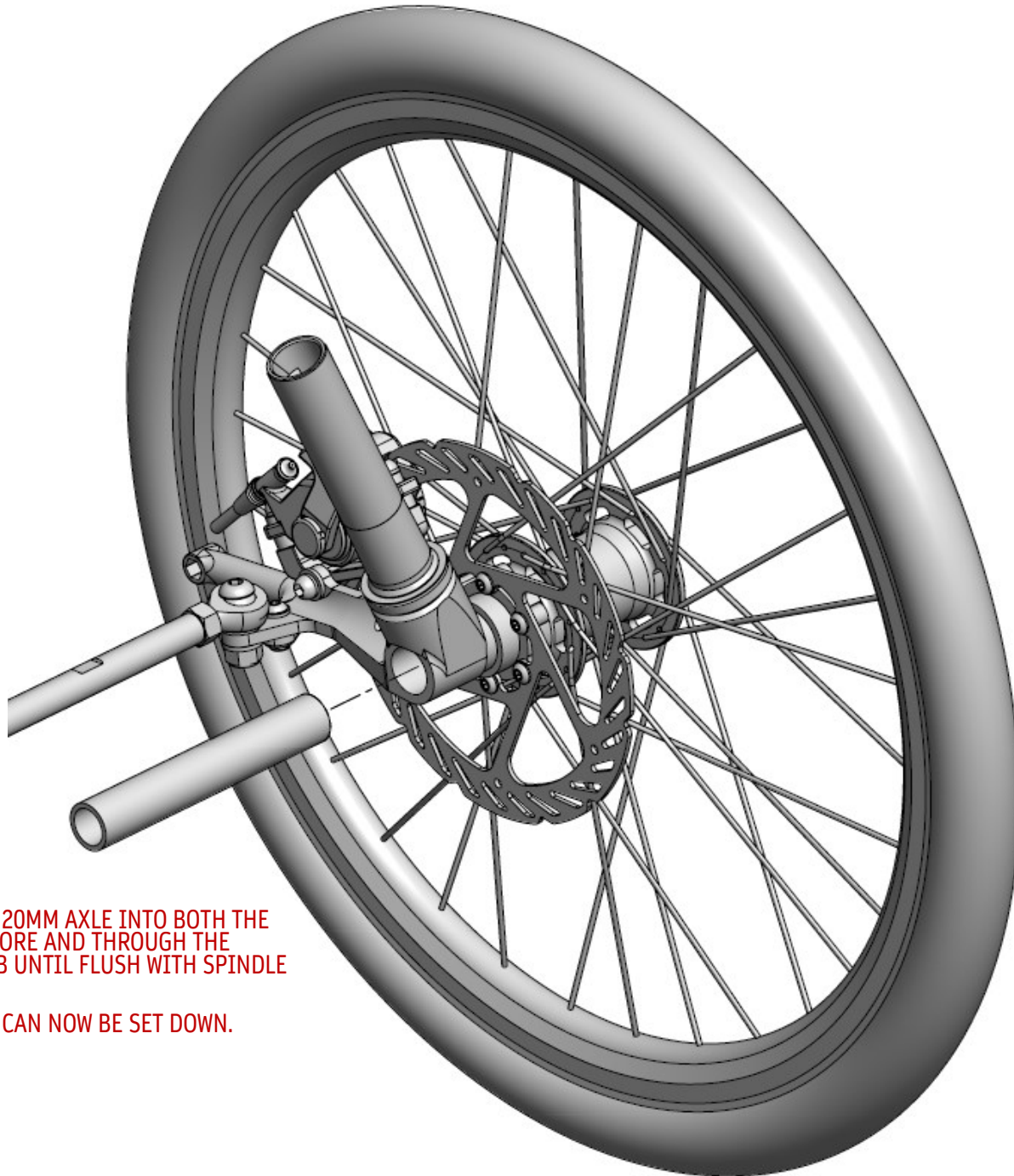

SLIDE THE 20MM AXLE INTO BOTH THE SPINDLE BORE AND THROUGH THE WHEEL HUB UNTIL FLUSH WITH SPINDLE SURFACE.

THE TRIKE CAN NOW BE SET DOWN.

WHEEL INSTALL STEP 3

INSTALL A SPRING ON EACH
SIDE OF THE AXLE ASSEMBLY.

INSTALL THE QUICK RELEASE
SKEWER SO THAT THE HANDLE
IS ON THE INSIDE OF THE
SPINDLE AND THE AXLE NUT
IS ON THE OUTSIDE OF THE
HUB.

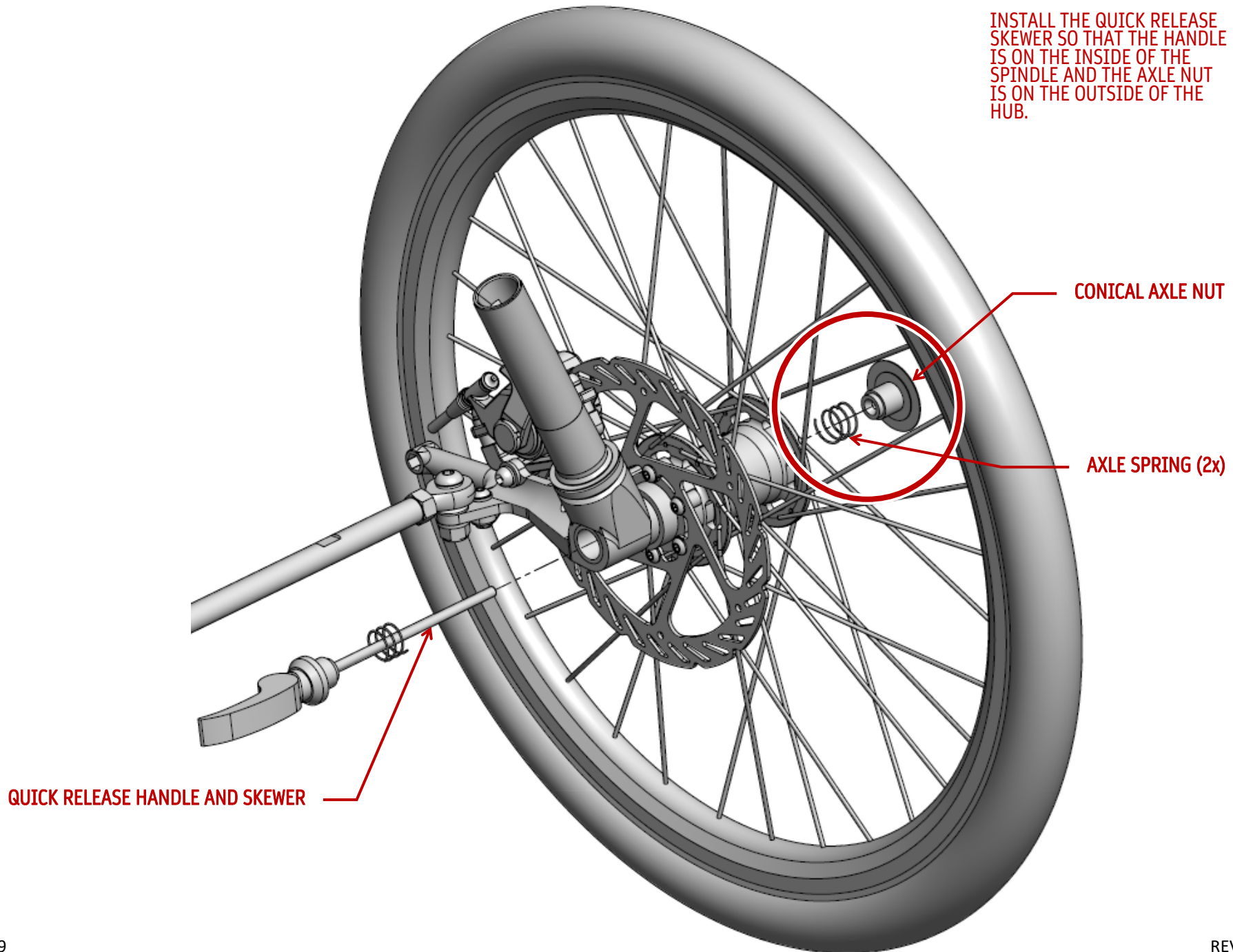

WHEEL INSTALL STEP 4



FOR YOUR SAFETY

CLOSE THE QUICK RELEASE HANDLE SO THAT IT POINTS TO THE REAR OF THE TRIKE

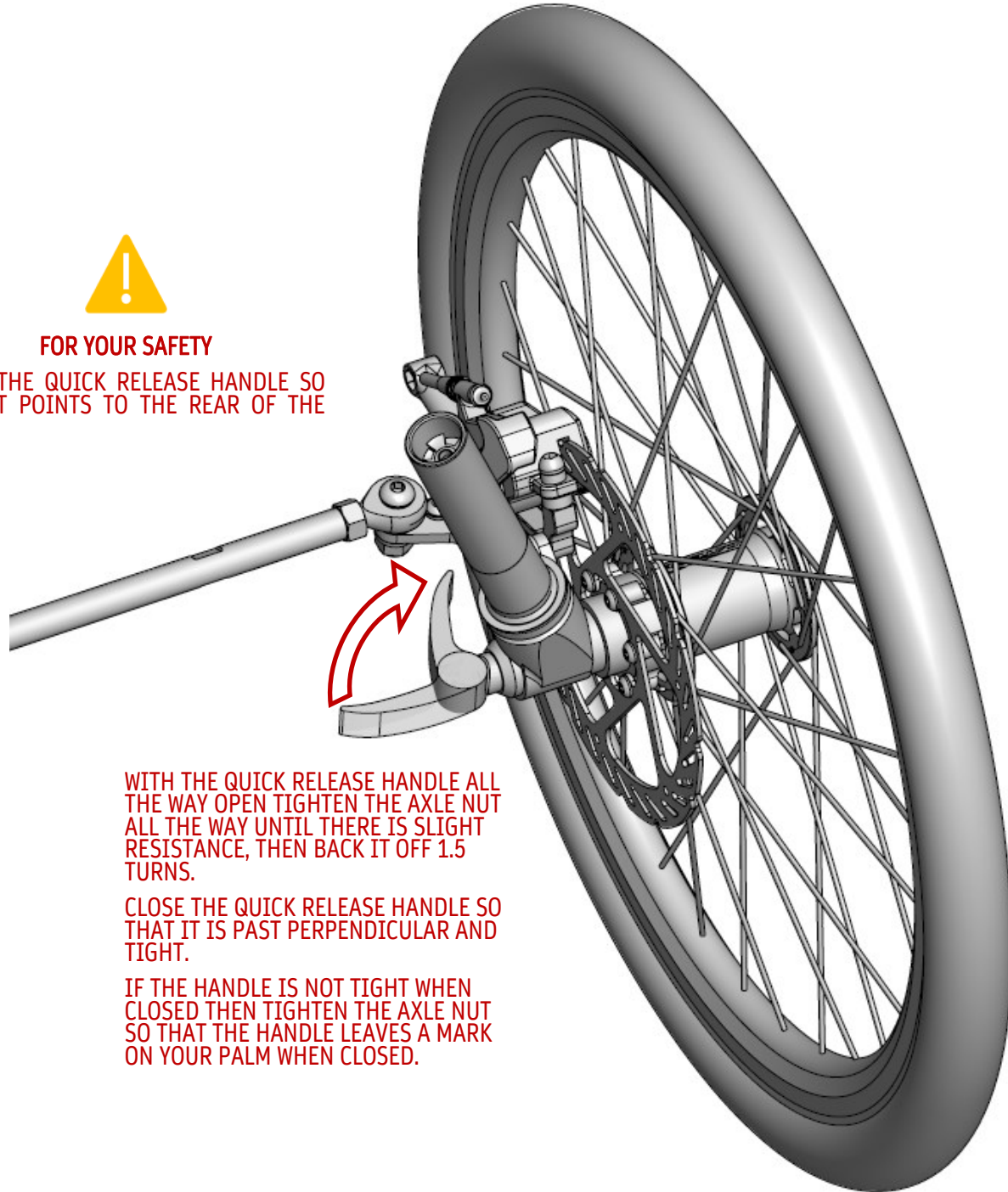

WITH THE QUICK RELEASE HANDLE ALL THE WAY OPEN TIGHTEN THE AXLE NUT ALL THE WAY UNTIL THERE IS SLIGHT RESISTANCE, THEN BACK IT OFF 1.5 TURNS.

CLOSE THE QUICK RELEASE HANDLE SO THAT IT IS PAST PERPENDICULAR AND TIGHT.

IF THE HANDLE IS NOT TIGHT WHEN CLOSED THEN TIGHTEN THE AXLE NUT SO THAT THE HANDLE LEAVES A MARK ON YOUR PALM WHEN CLOSED.

THRU AXLE HUB & HANGER INSTALL



TIP:

IF INSTALLED, SHIFT REAR DERAILLEUR TO SMALLEST COG TO MAKE TIRE INSTALL AND REMOVAL EASIER

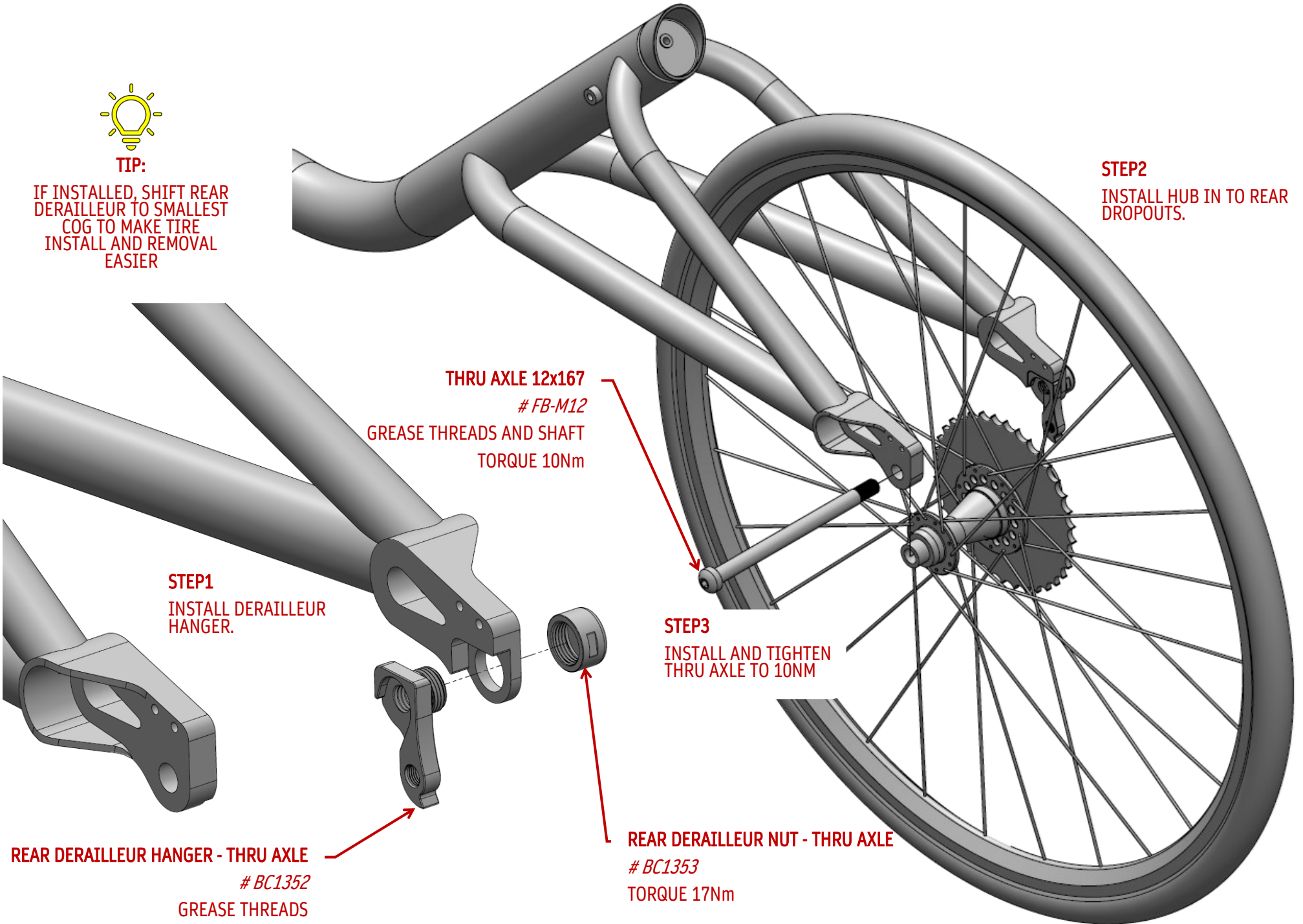

STEP2

INSTALL HUB IN TO REAR DROPOUTS.

THRU AXLE 12x167

FB-M12

GREASE THREADS AND SHAFT
TORQUE 10Nm

STEP1

INSTALL DERAILLEUR
HANGER.

STEP3

INSTALL AND TIGHTEN
THRU AXLE TO 10NM

REAR DERAILLEUR HANGER - THRU AXLE

BC1352

GREASE THREADS

REAR DERAILLEUR NUT - THRU AXLE

BC1353

TORQUE 17Nm

TIE-ROD ADJUSTMENT



THE PURPOSE OF SETTING THE CORRECT TOE IS TO KEEP THE TIRES LASTING AS LONG AS POSSIBLE AND FOR THE TRIKE TO HANDLE CORRECTLY.

IT IS RECOMMENDED TO MEASURE AND ADJUST THE TOE WHILE SITTING ON THE TRIKE. THIS WILL ENSURE THE PERFECT TOE SETTING.

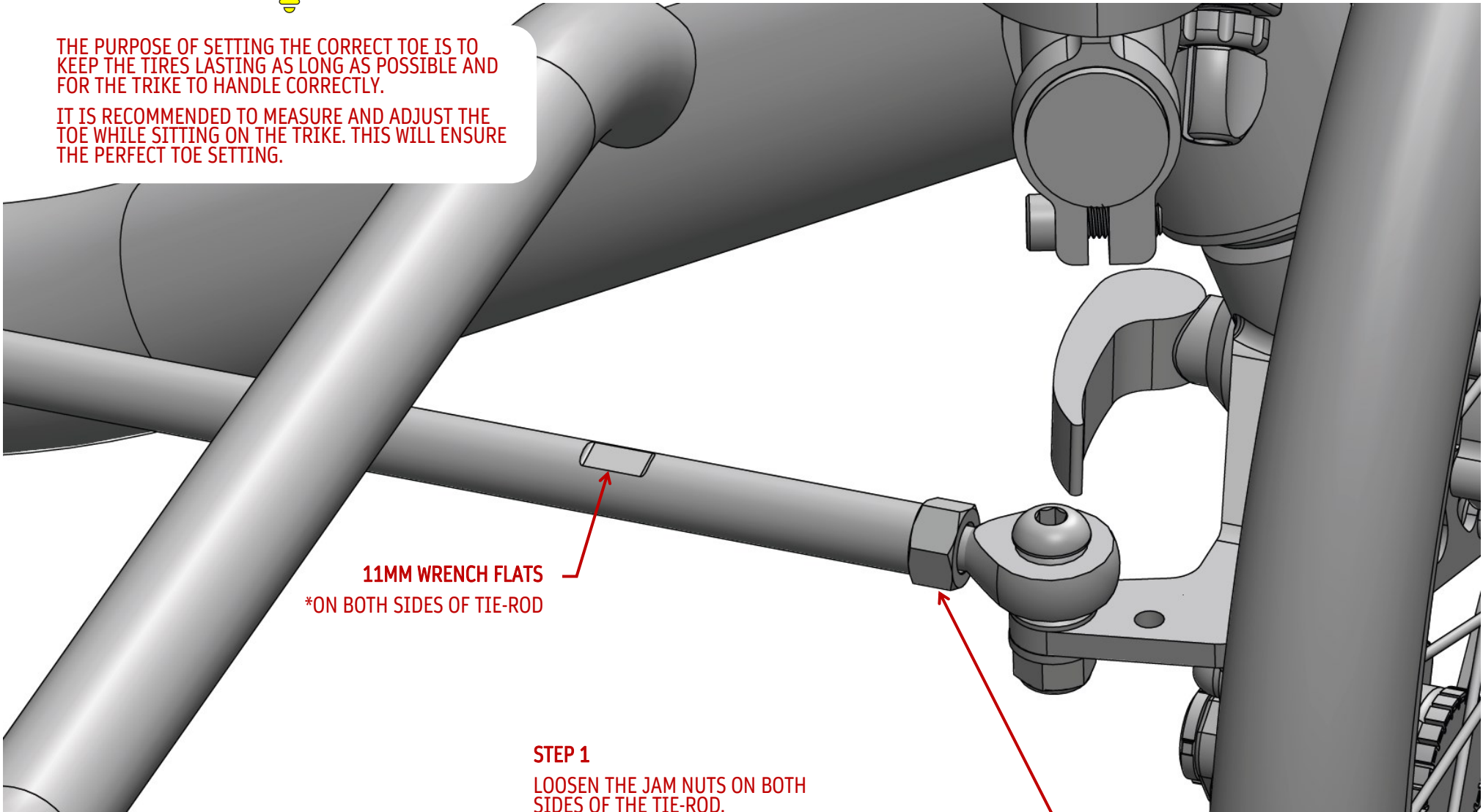

11MM WRENCH FLATS
*ON BOTH SIDES OF TIE-ROD

STEP 1

LOOSEN THE JAM NUTS ON BOTH SIDES OF THE TIE-ROD.

NOTE THAT ONE SIDE OF THE TIE-ROD IS REVERSE THREADED.

JAM NUT - 14MM WRENCH
*ONE SIDE IS REVERSE THREADED

TIE-ROD ADJUSTMENT CONTINUED

STEP 2

WITH THE WHEELS POINTING AS STRAIGHT AS POSSIBLE, USE THE CALIBRO OR A TAPE MEASURE TO MEASURE ACROSS THE FRONT WHEELS AT THE RIM FROM AXLE HEIGHT; TWO POINTS CIRCLED BELOW.

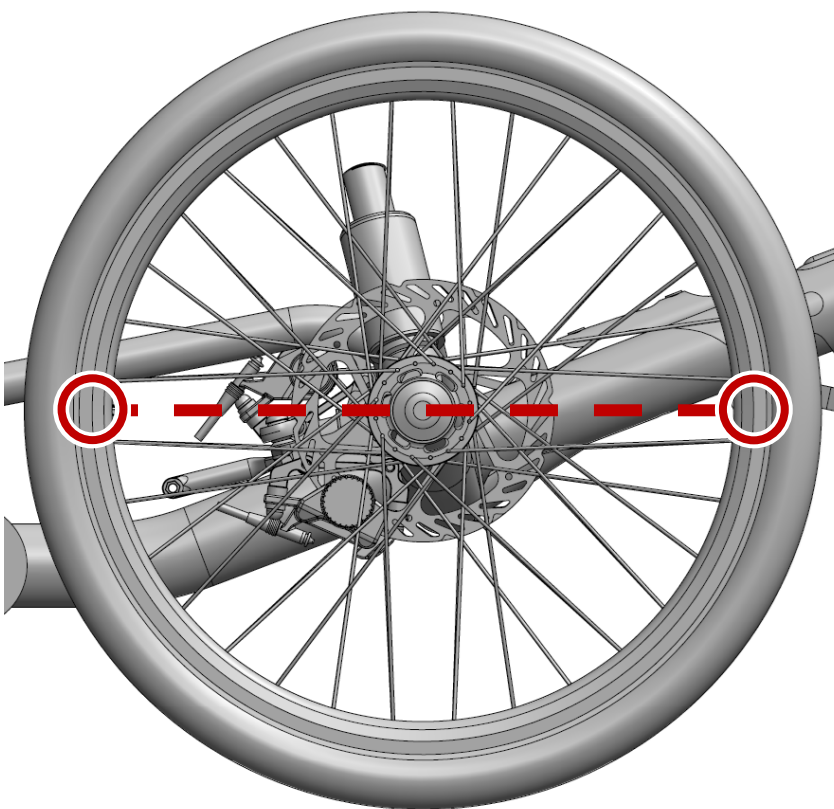

STEP 3

COMPARE THE MEASUREMENTS FROM BOTH SIDES, ADJUST THE TIE-ROD BY SPINNING THE MAIN BODY SO THAT THE FRONT AND REAR MEASUREMENT ARE EQUAL WHILE SITTING ON THE TRIKE.

IF IT IS NOT POSSIBLE TO SIT ON THE TRIKE WHILE ADJUSTING TOE, THEN TOE THE WHEELS IN 2MM. IN OTHER WORDS THE MEASUREMENT FROM THE FRONT SHOULD BE 2MM SMALLER THAN THE MEASUREMENT TAKEN FROM THE REAR OF THE RIM.

AS RIDER WEIGHT IS APPLIED TO THE CATRIKE THE TOE WILL BECOME MORE EQUAL.

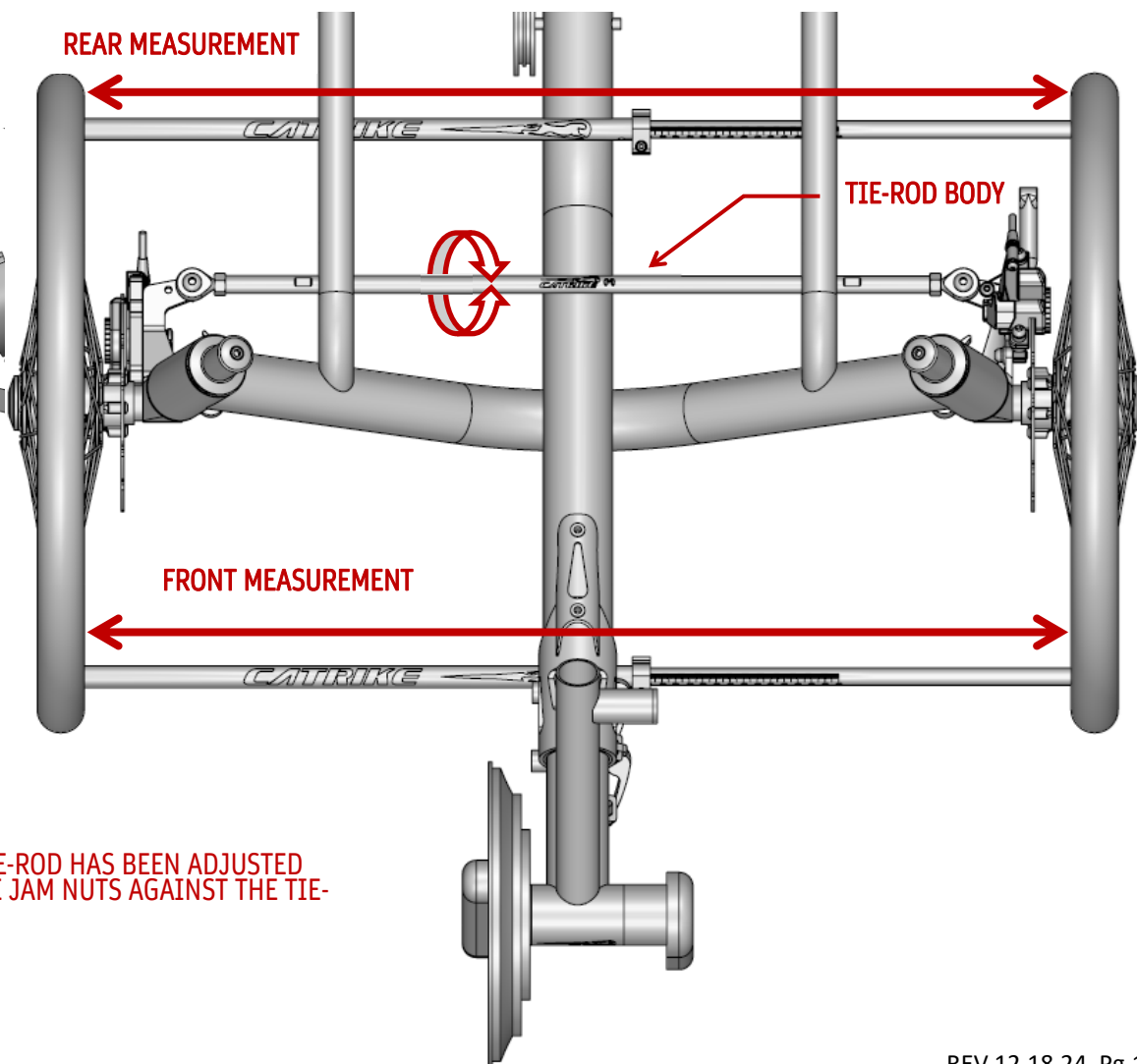

STEP 4

ONCE THE TIE-ROD HAS BEEN ADJUSTED TIGHTEN THE JAM NUTS AGAINST THE TIE-ROD BODY.

TALL HANDLEBAR ASSEMBLY RIGHT

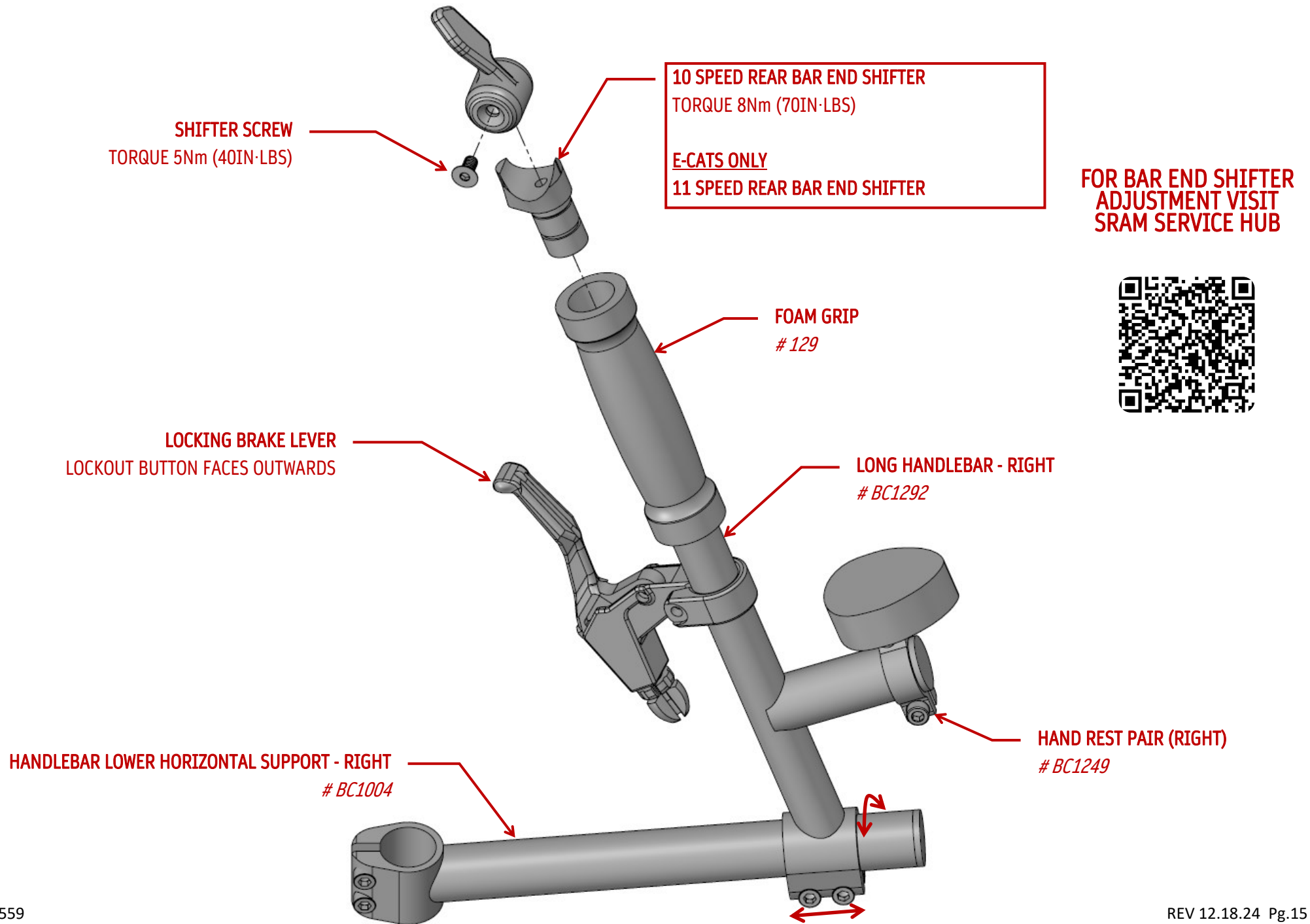

TALL HANDLEBAR ASSEMBLY LEFT

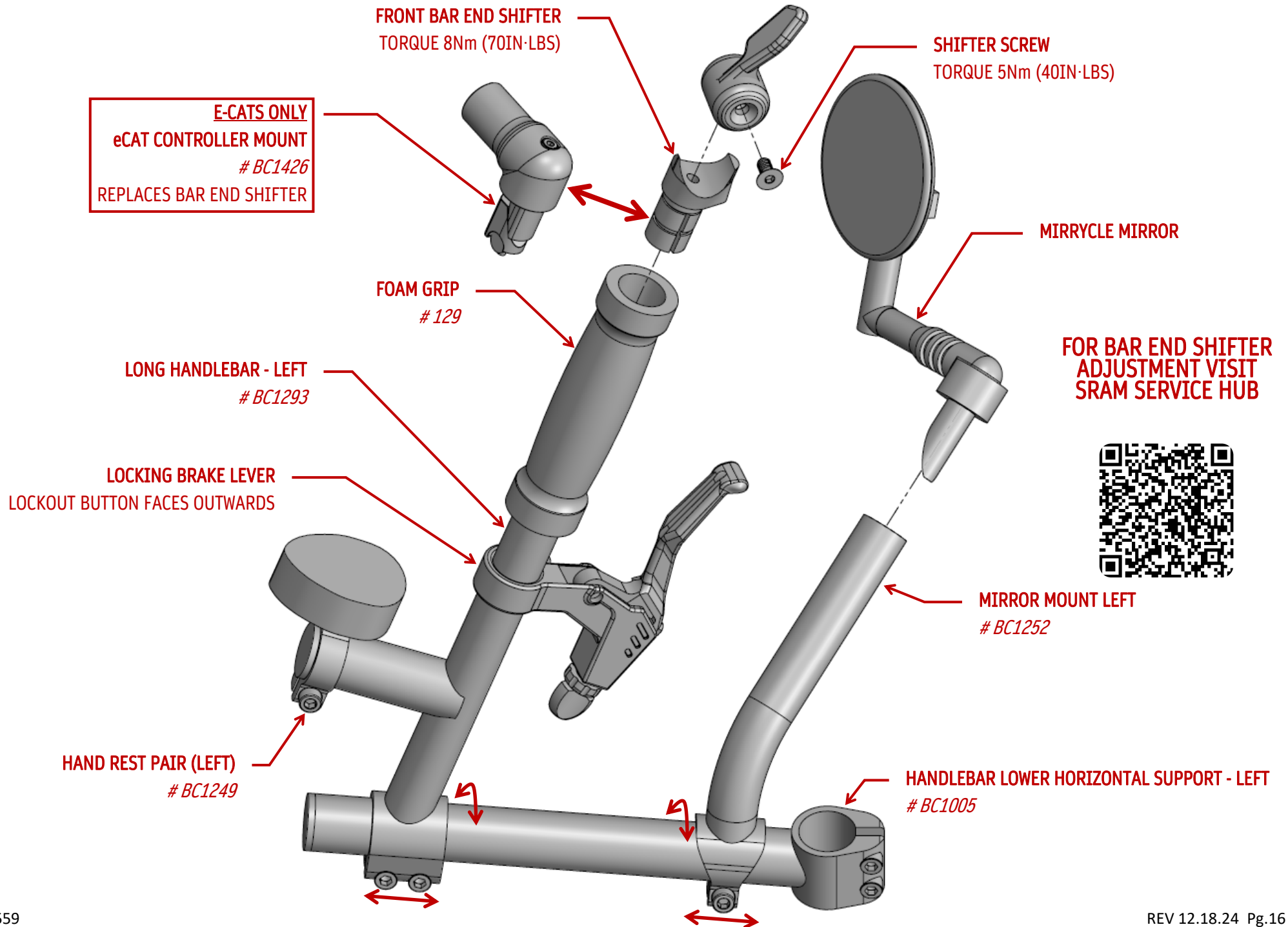

FOR BAR END SHIFTER
ADJUSTMENT VISIT
SRAM SERVICE HUB



BOOM ADJUSTMENT



WHILE SITTING, SLIDE BOOM UP TO HEEL OF FULLY EXTENDED LEG.

BOOM CAN BE CUT FOR SHORTER RIDERS.



ONCE CLIPPED IN, THE EXTENDED LEG SHOULD NOW HAVE A SLIGHT BEND.

BOOM ADJUSTMENT IS UP TO RIDER PREFERENCE.

CLOSE BOOM CLAMP BY TIGHTENING THE QUICK RELEASE NUTS ON BOTH LEVERS AND FULLY CLAMPING EACH HANDLE.

THE BOOM SHOULDN'T ROTATE WHILE PEDALING.

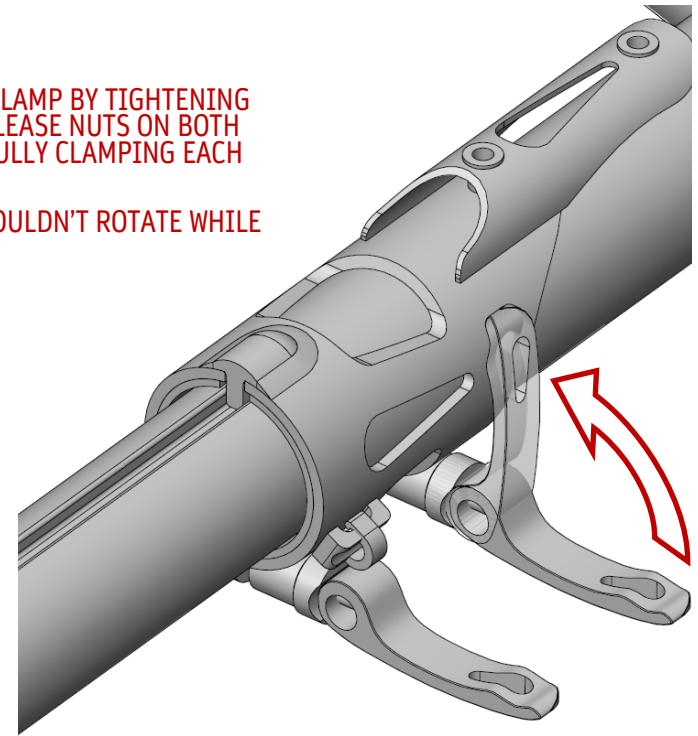

CLIPLESS SHOES ARE STRONGLY RECCOMENDED

SEE WARNING ON NEXT PAGE REGARDING MINIMUM BOOM INSERTION

BOOM INSERTION

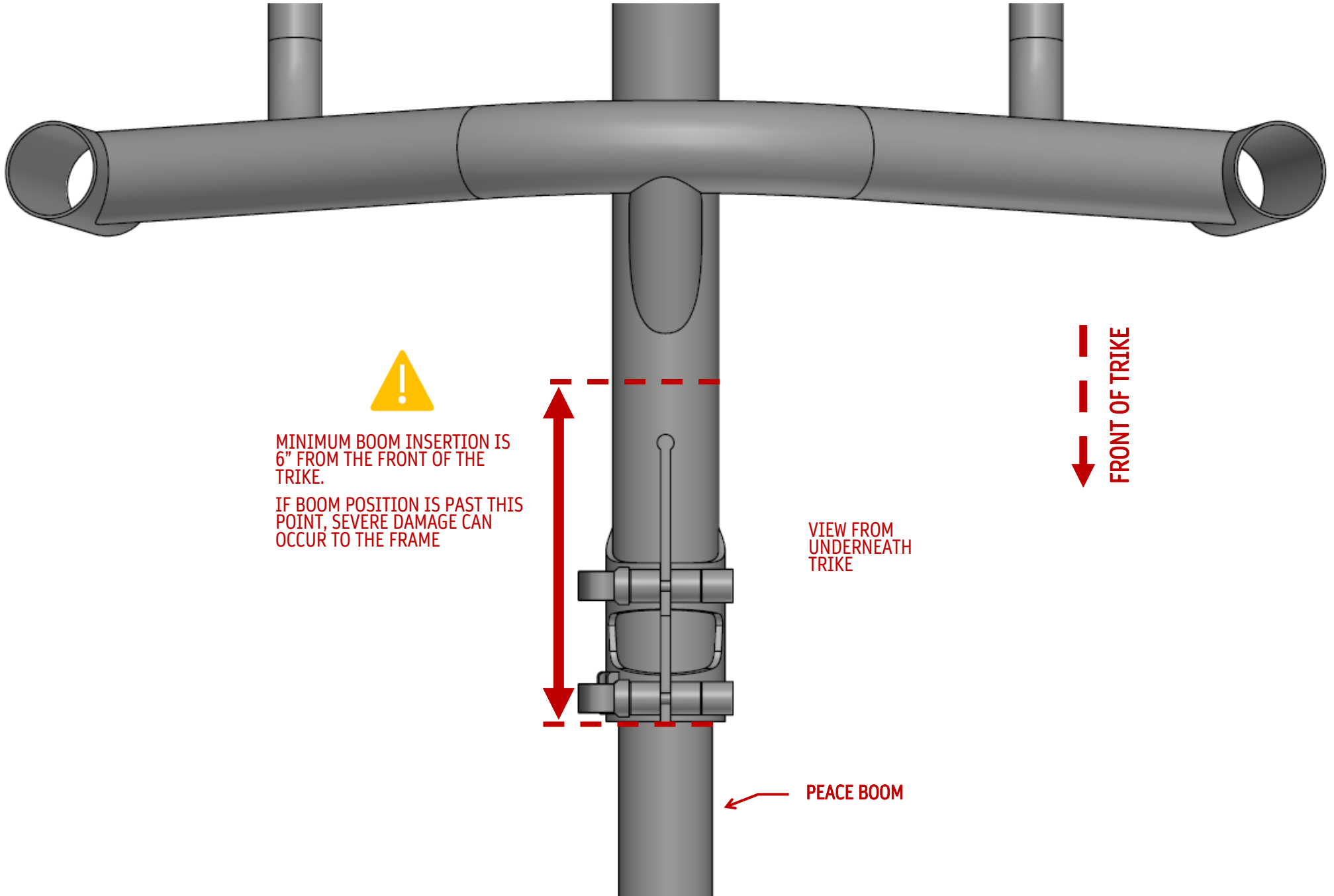

CABLE ROUTING

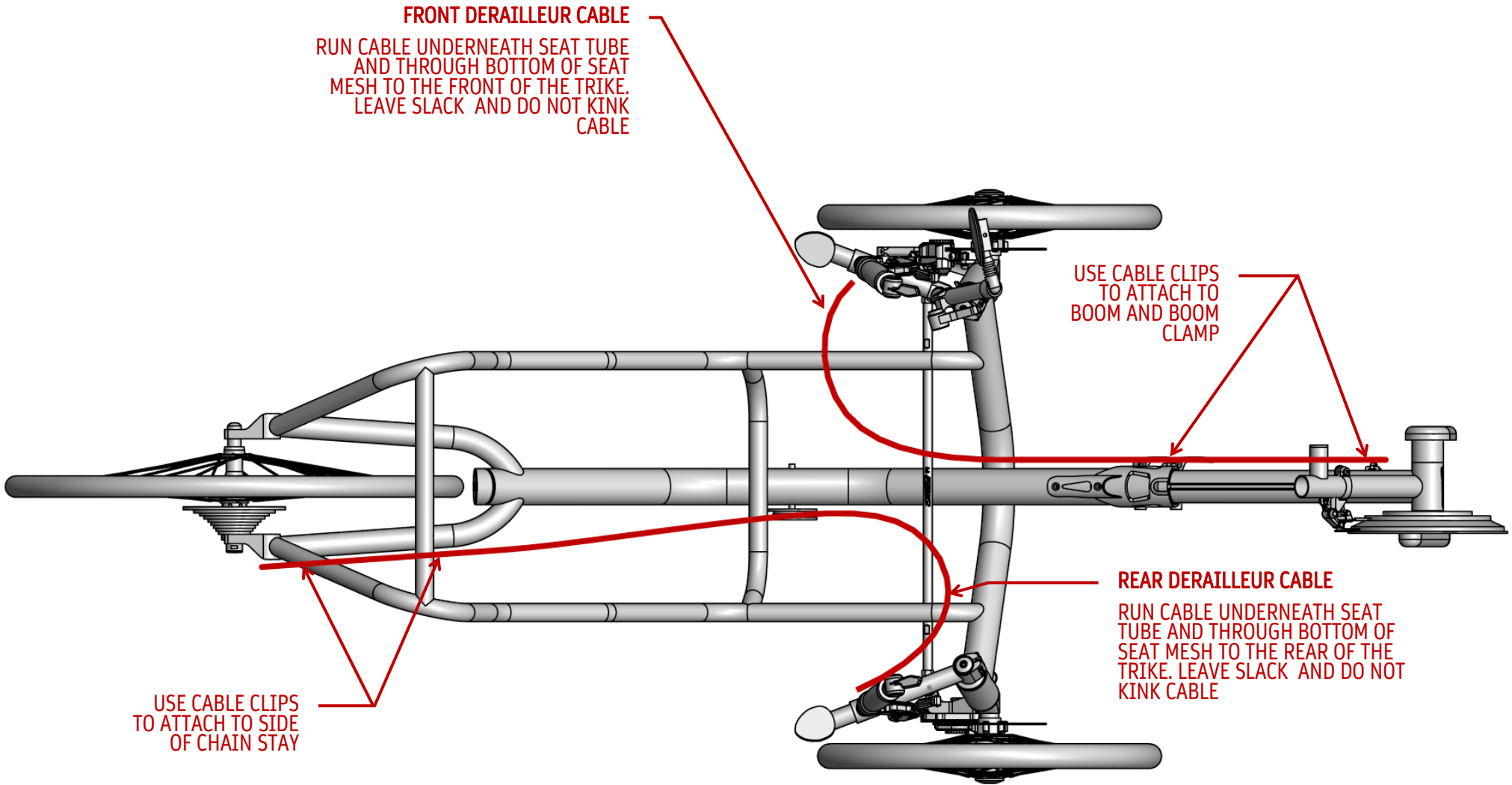

CHAIN ROUTING

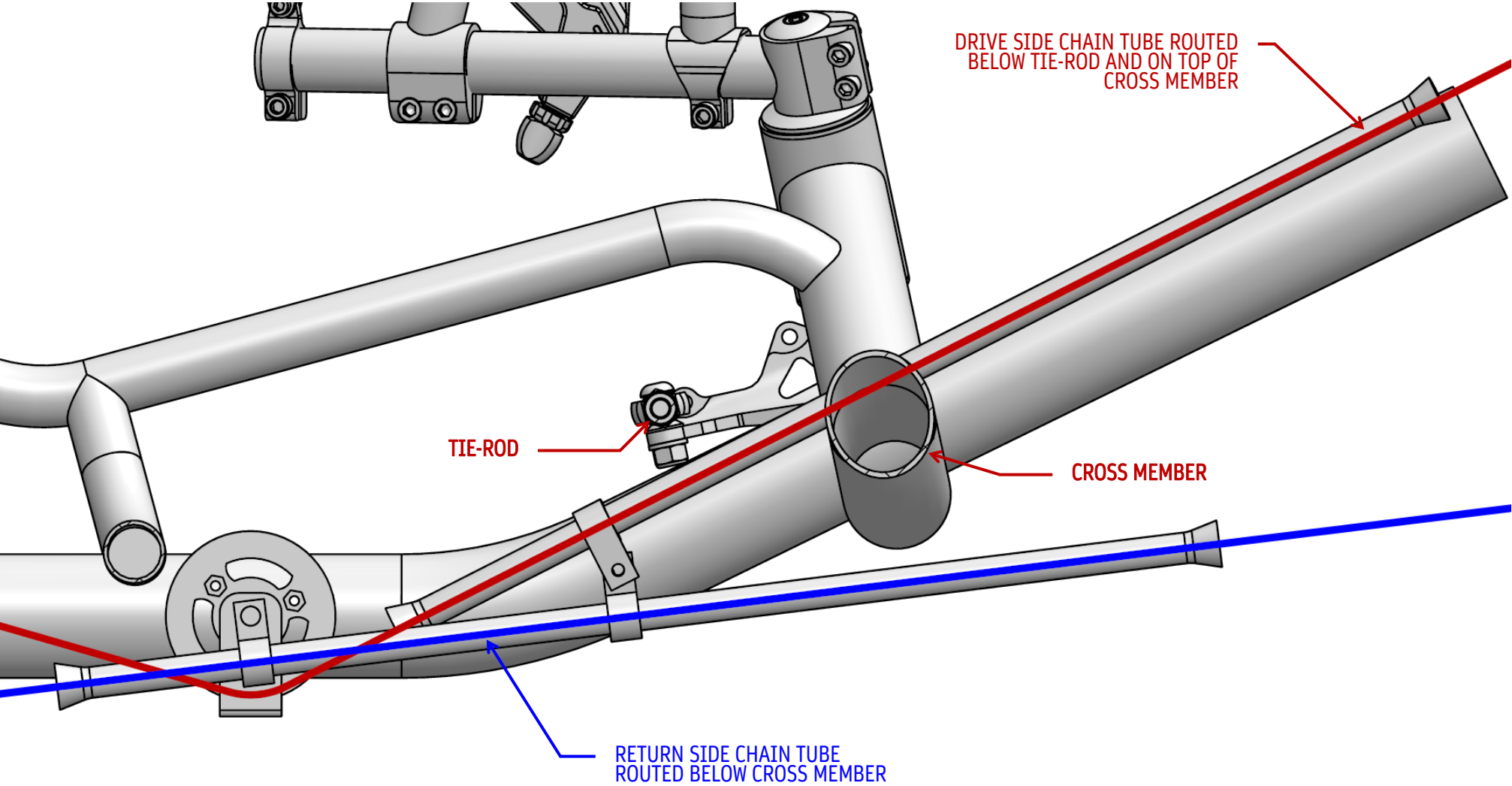

ERGO ADJUSTABLE SEATBACK & ROLLER WHEEL ASSEMBLY



LEFT SIDE SHOWN,
RIGHT SIDE MIRRORED

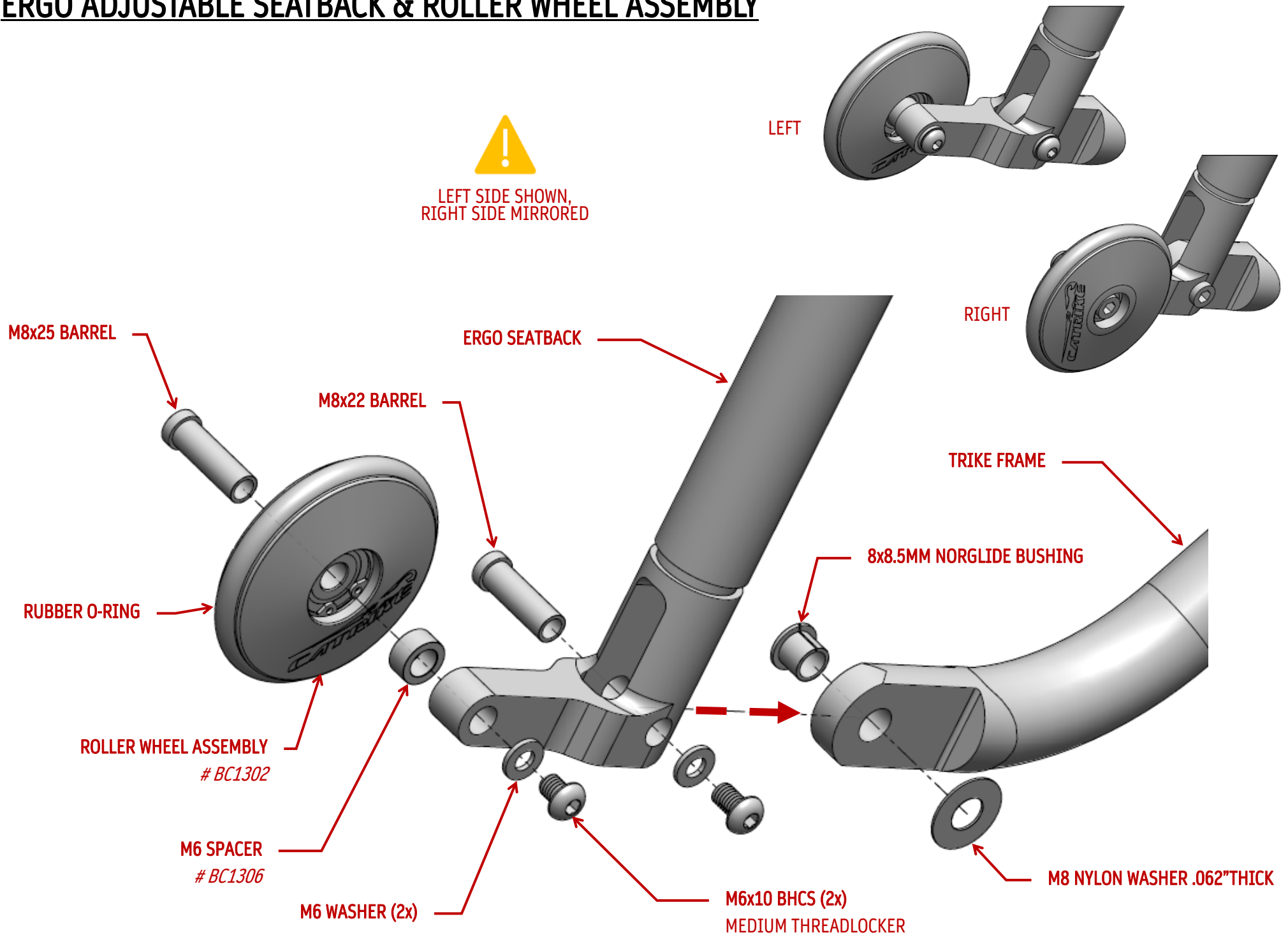

ADJUSTABLE SEATBACK FORK ASSEMBLY

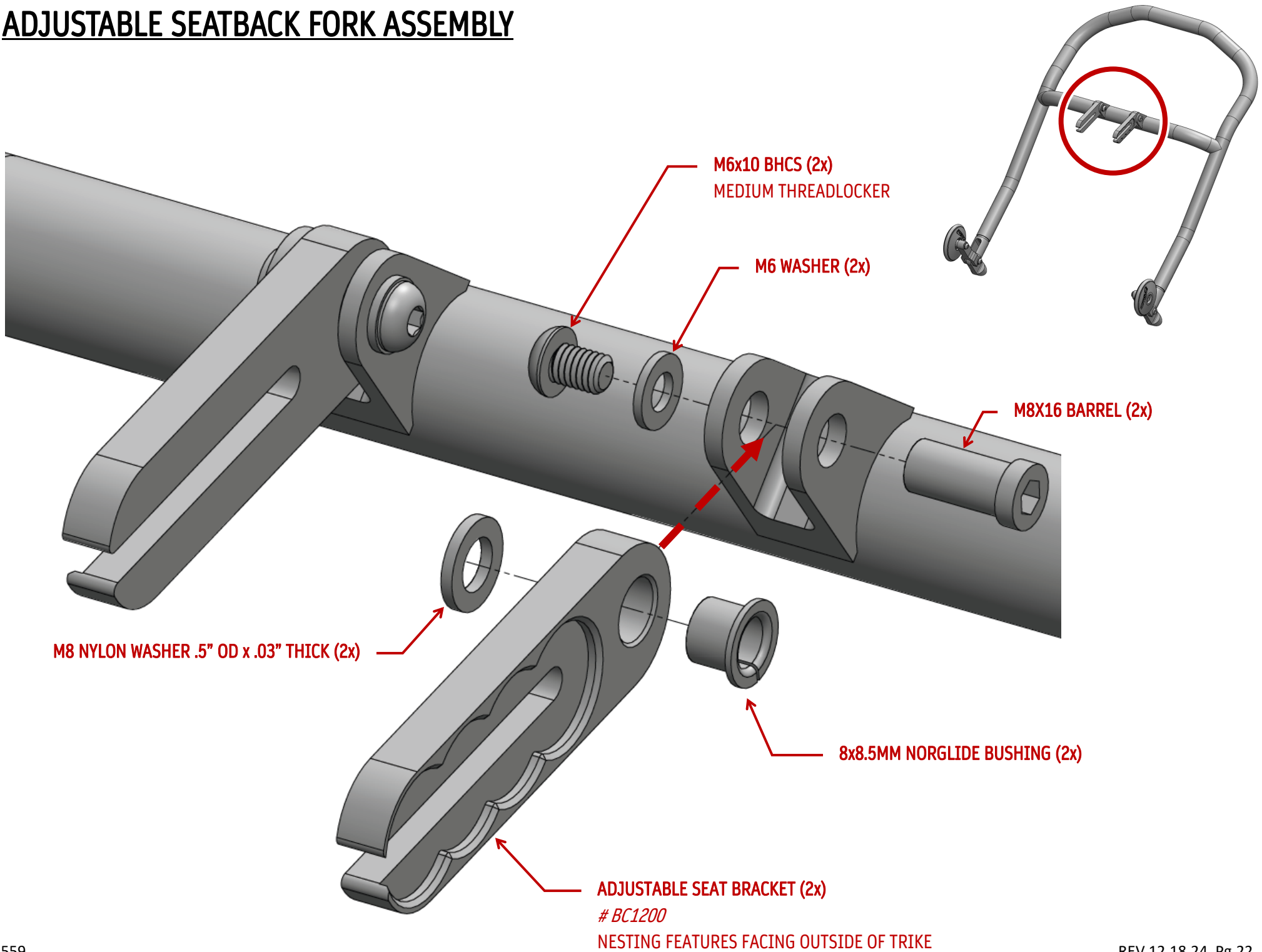

ADJUSTABLE SEATBACK ADJUSTMENT

STEP1

OPEN THE SEATBACK QUICK RELEASE AND LOOSEN THE QUICK RELEASE NUT UNTIL THE SEATBACK FORKS CAN MOVE FREELY

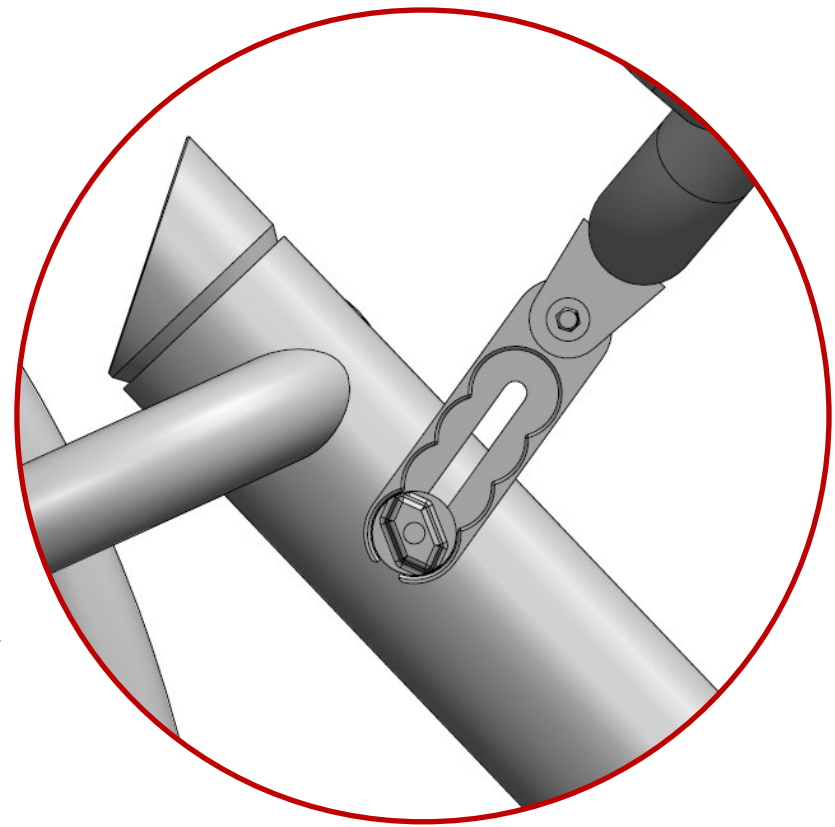
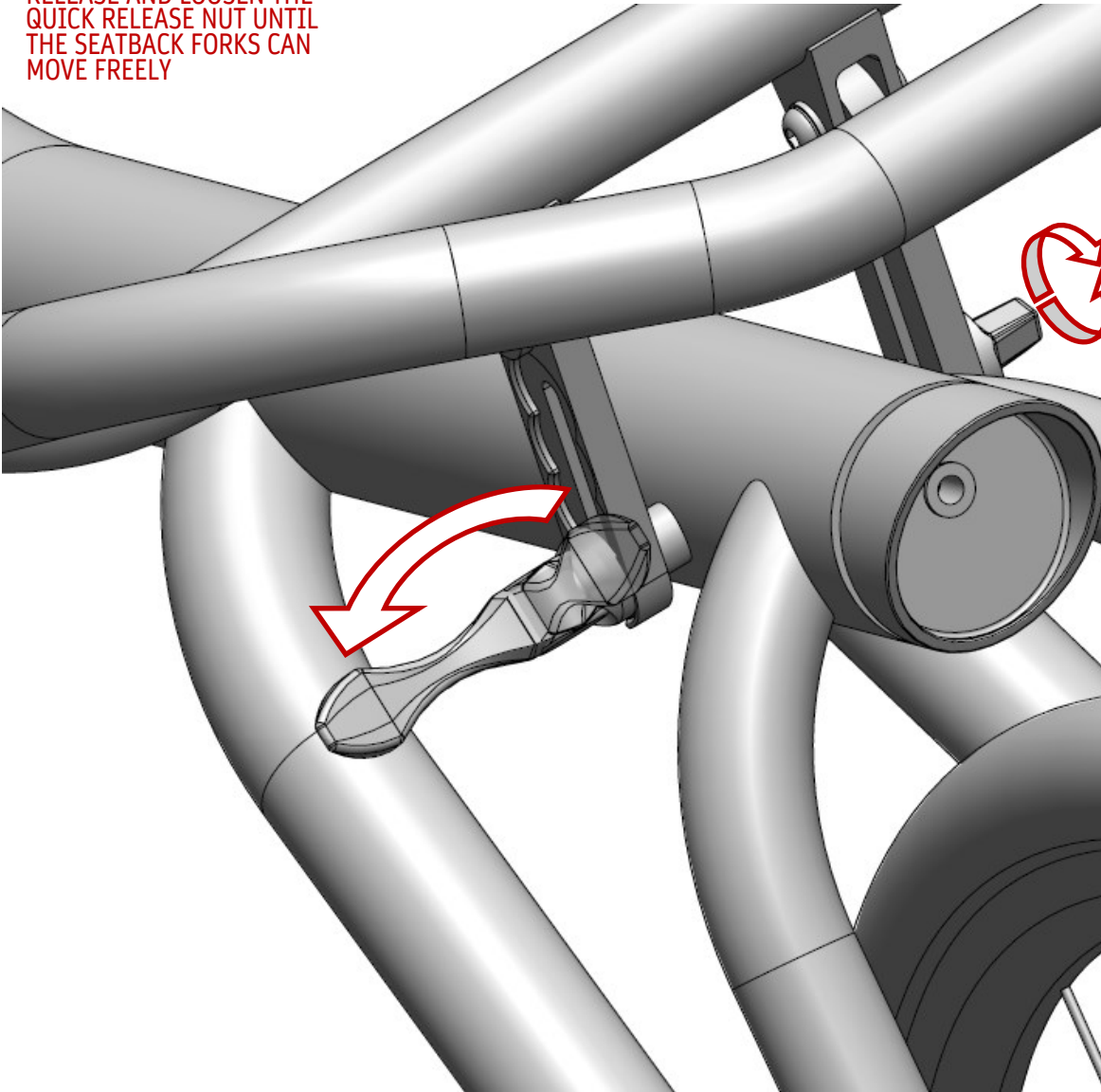

STEP2

SLIDE THE SEAT INTO ONE OF THE FOUR POSITIONS ON THE ADJUSTMENT FORK

STEP3

TIGHTEN QUICK RELEASE NUT SO THAT WHEN CLOSING THE QUICK RELEASE HANDLE THE SEATBACK DOES NOT MOVE

FOLDING HINGE HARDWARE

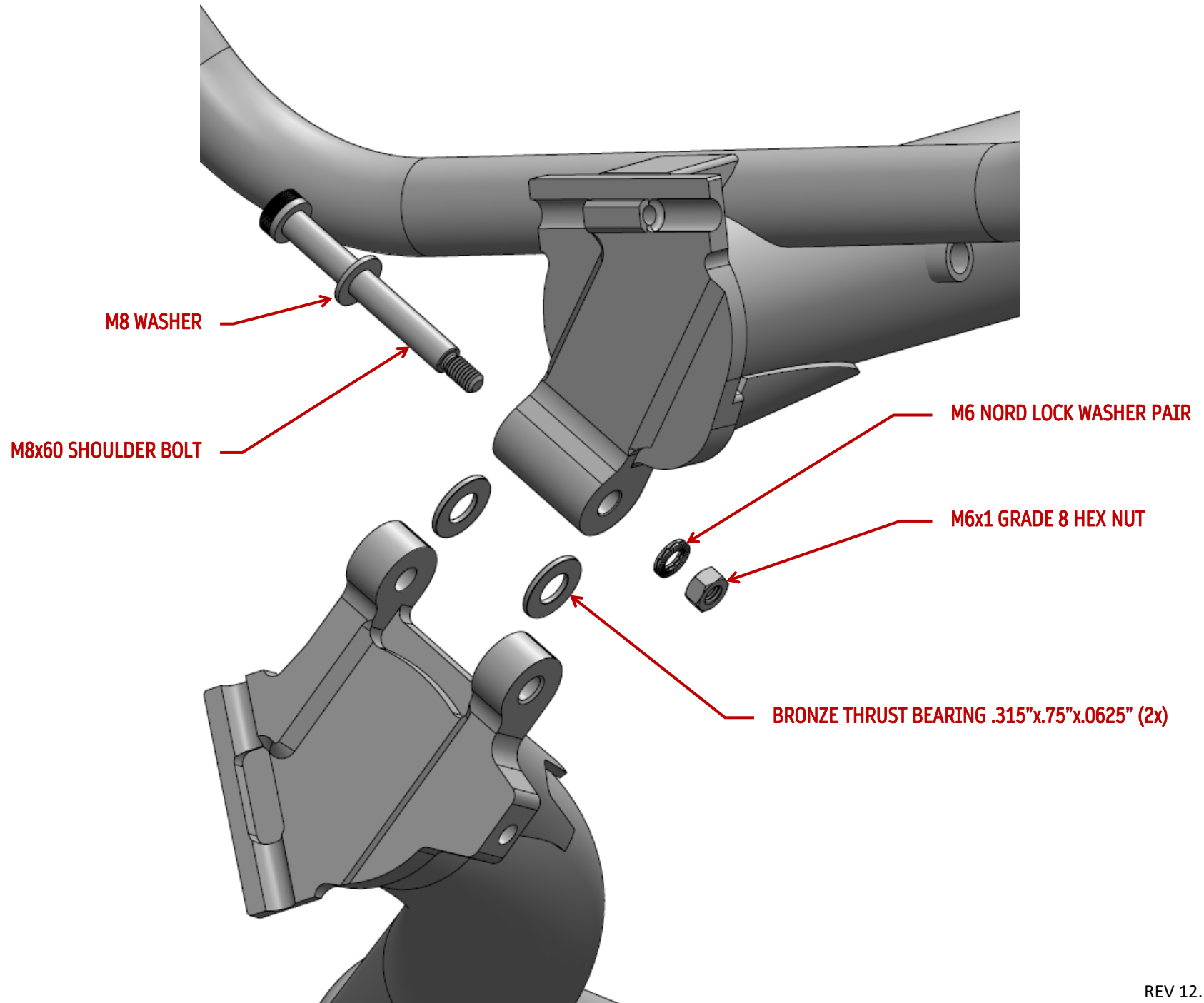

FOLDING HINGE QUICK RELEASE

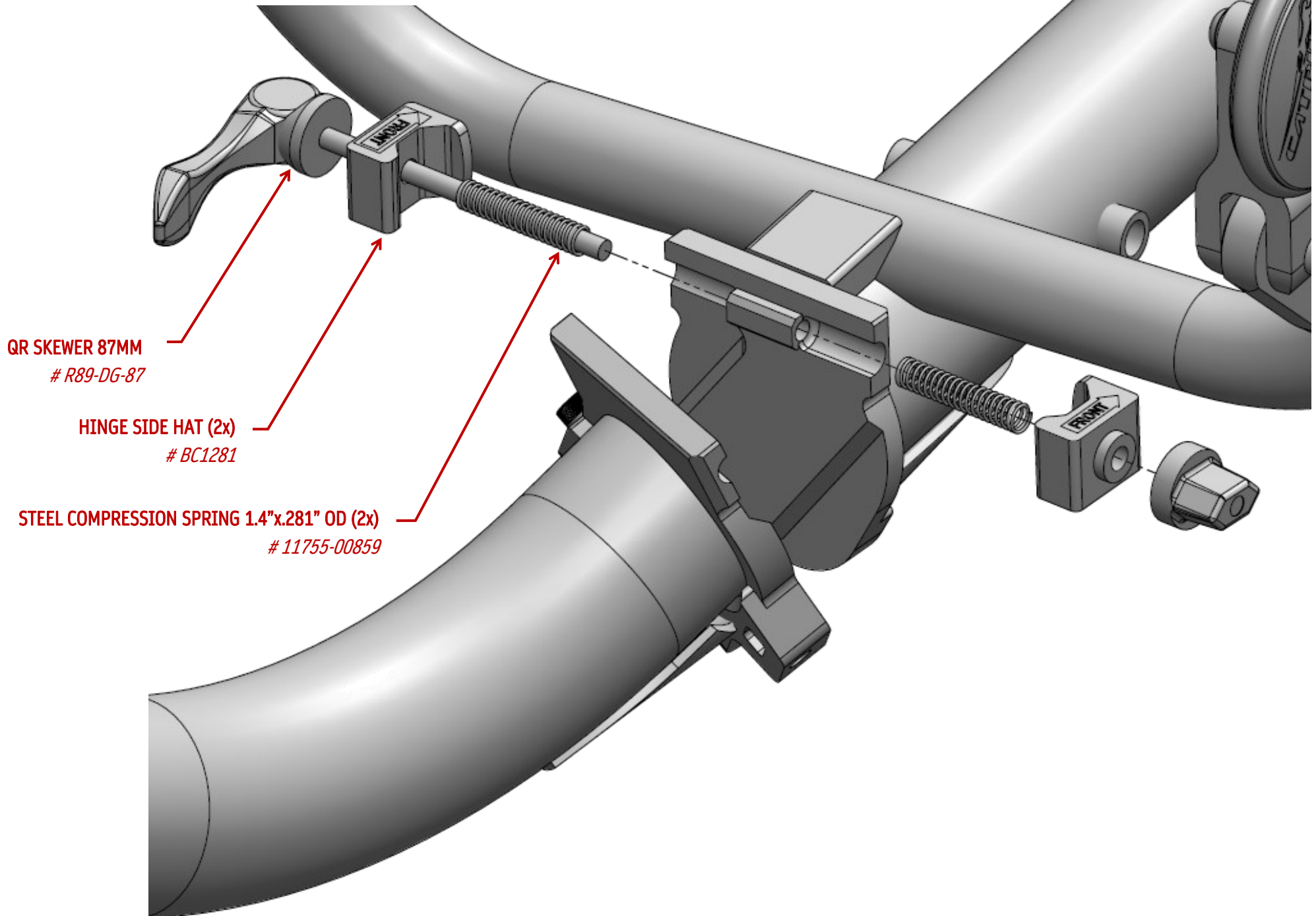

FOLDING CHAIN-STAY LOCK

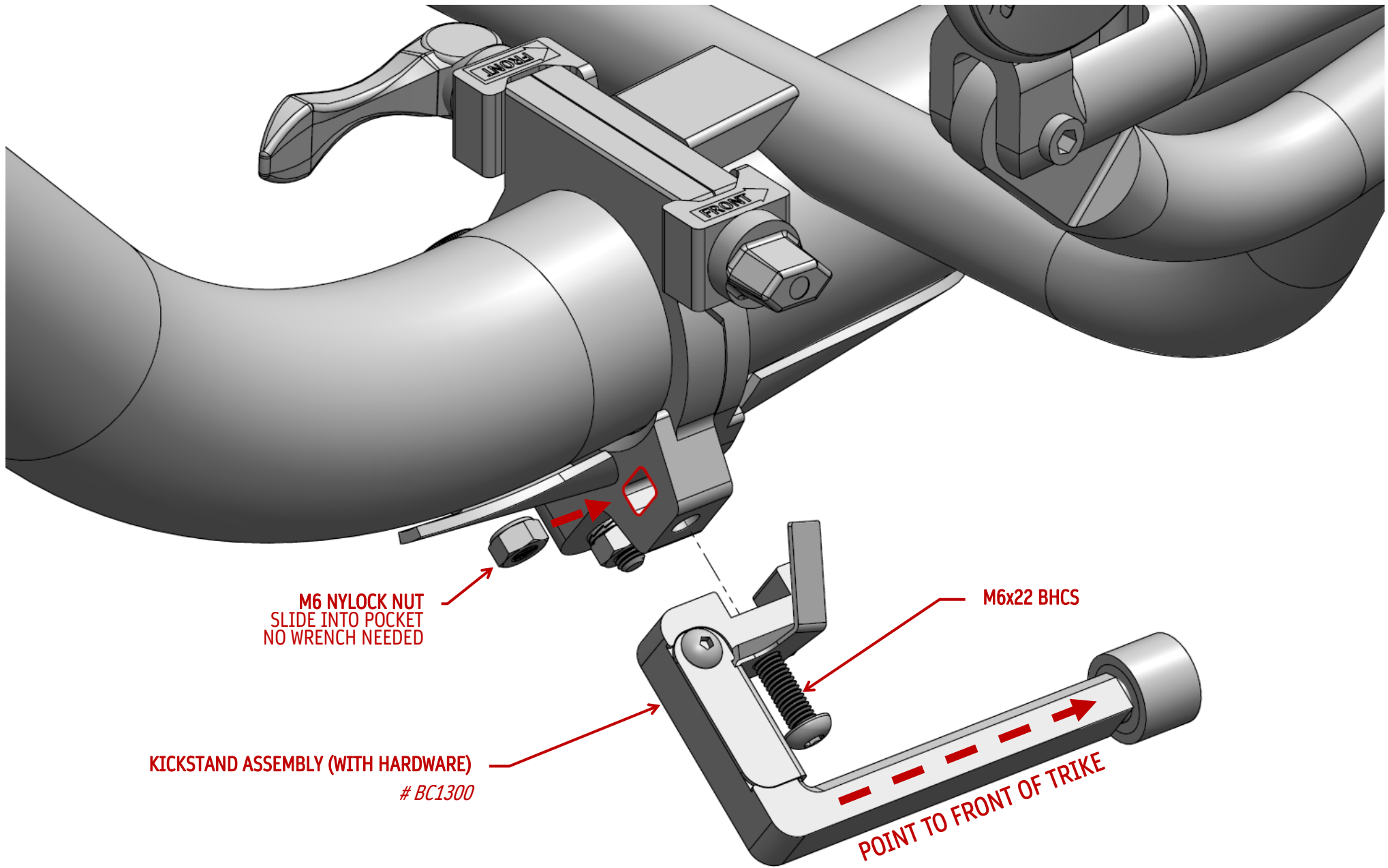

FOLDING CHAIN-STAY LOCK

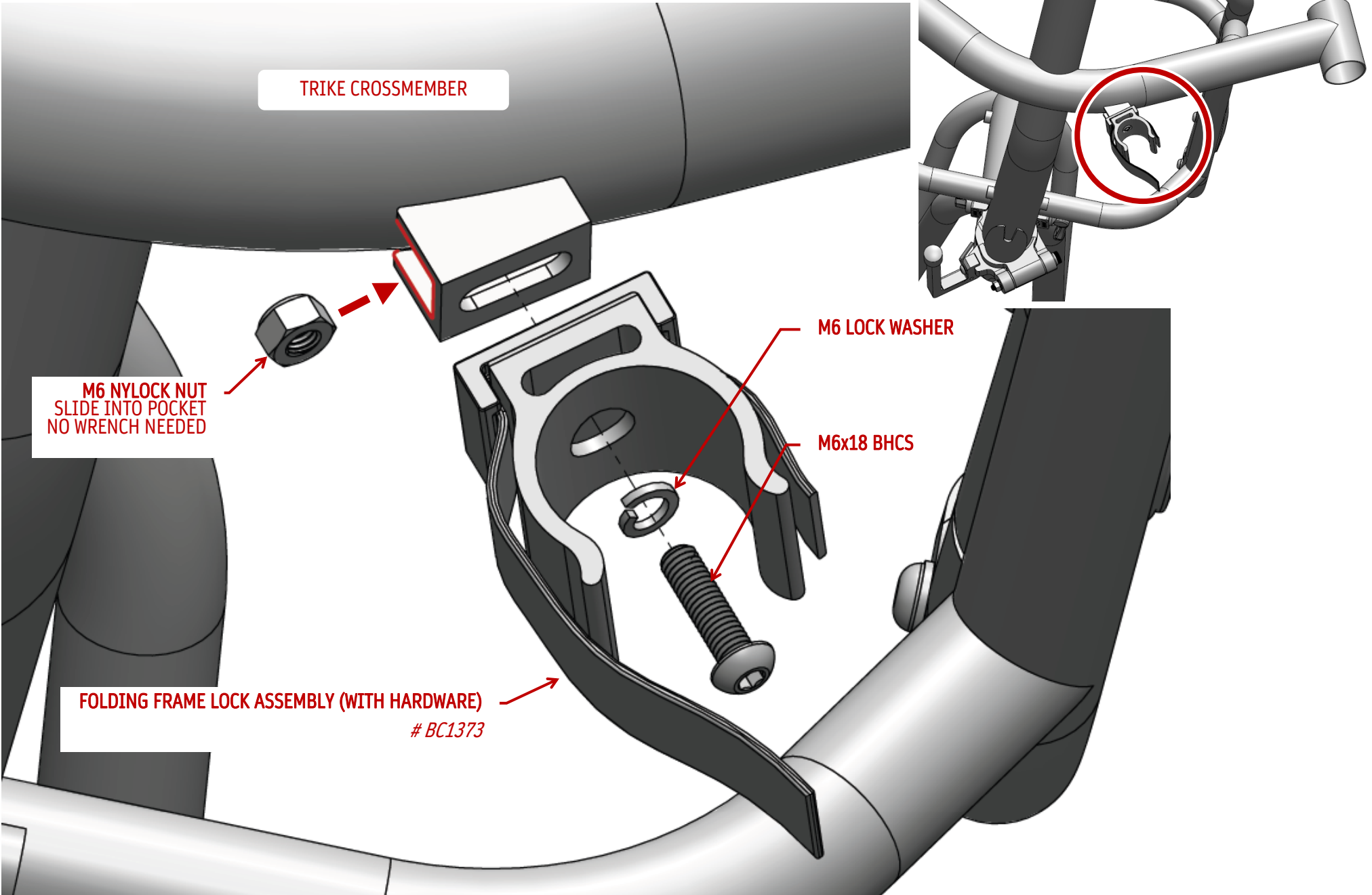

EKIT BATTERY CLAMP ASSEMBLY

DO NOT TIGHTEN
BOLTS ALL THE
WAY YET

BATTERY MOUNT CLAMP WELDED
BC1419

BATTERY MOUNT CLAMP SHIM
BC1423
WRAP AROUND MAINFRAME TUBE

BATTERY MOUNT OUTER CLAMP
BC1420

M6 SMALL OD WASHER (2x)

M6x25 SHCS (2x)
LIGHTLY GREASE THREADS

EKIT BATTERY CLAMP POSITION

PLACE CLAMP BETWEEN THE CHAIN STAYS AND SEAT STAYS

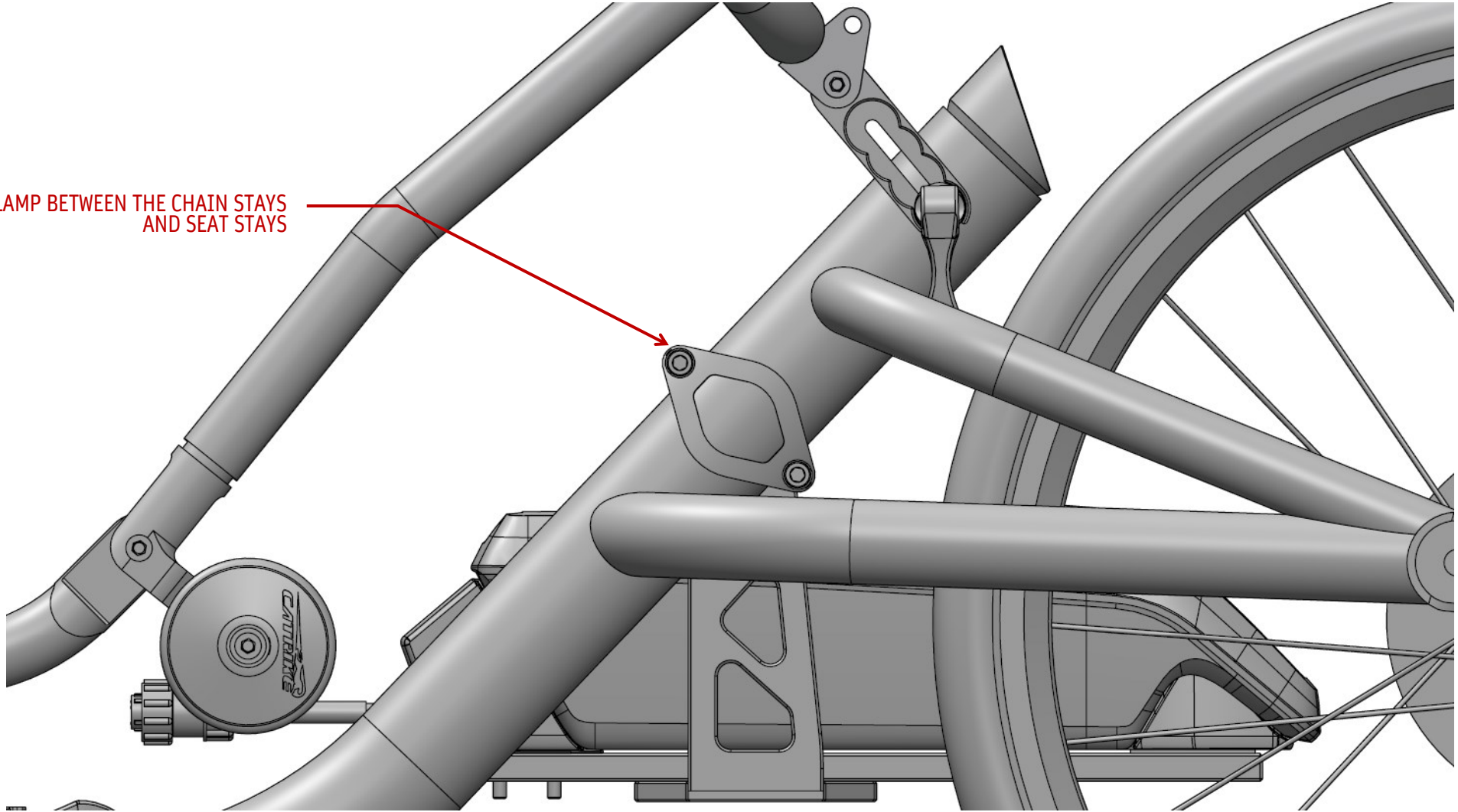

EKIT BATTERY RAIL POSITION

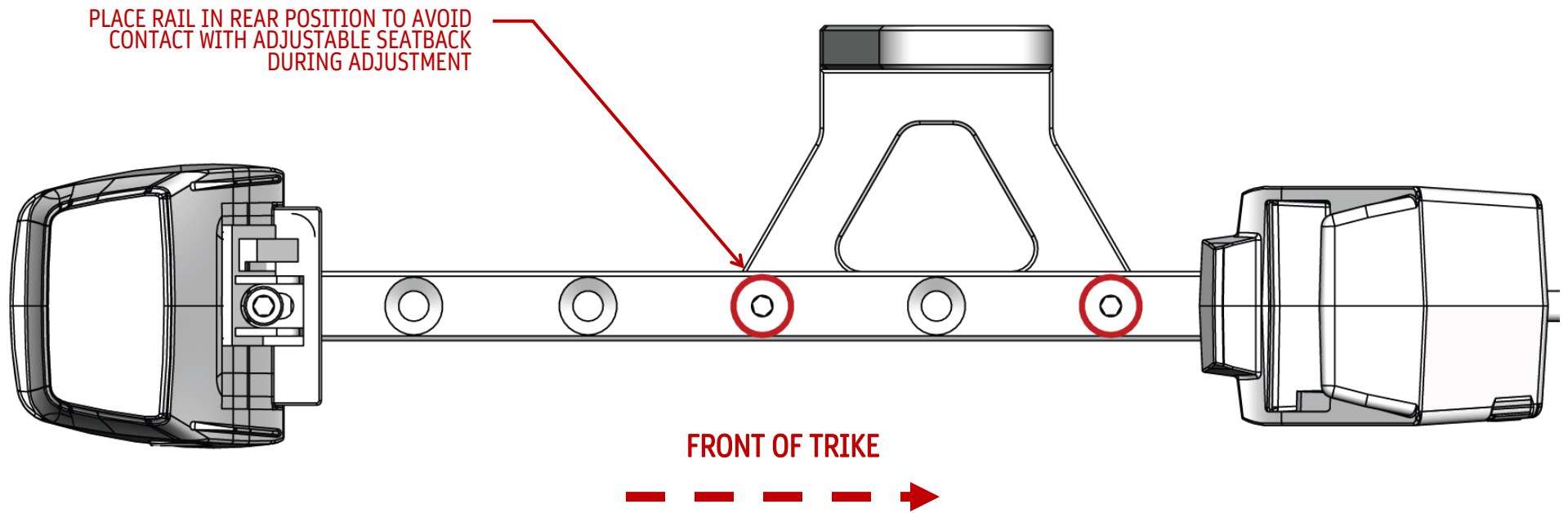

EKIT BATTERY RAIL ASSEMBLY



**DO NOT TIGHTEN
BOLTS ALL THE
WAY YET UNLESS
SPECIFIED**

M6 SMALL OD WASHER (2x)

**M6x16 BHCS (2x)
LIGHTLY GREASE THREADS**

**M6x16 FHCS (2x)
TORQUE 5Nm (40IN-LBS)**

**BATTERY MOUNT PLATE WELDED
BC1421**

BATTERY RAIL ASSEMBLY

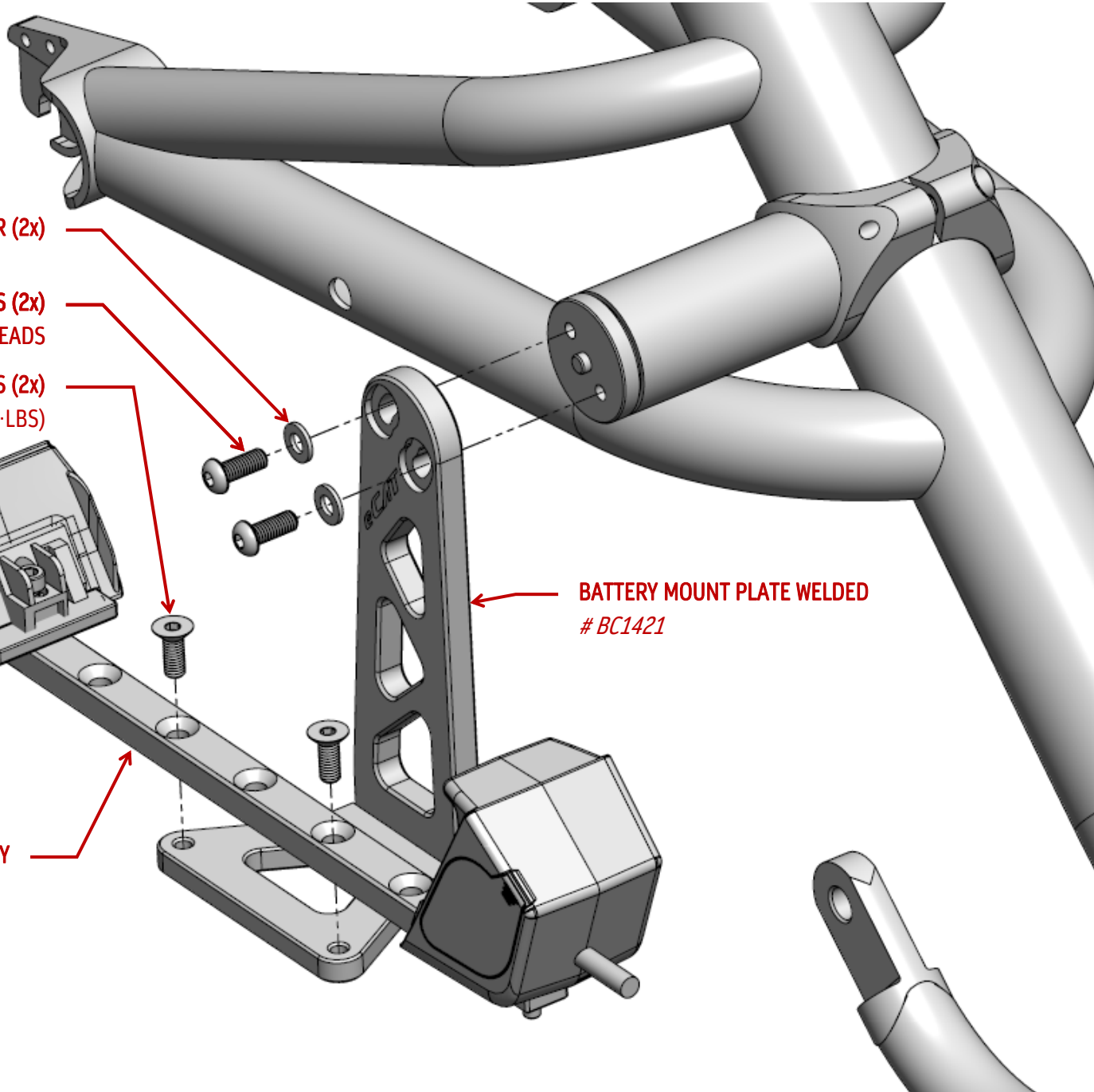

EKIT BATTERY CLAMP LEVEL

LEVEL EACH OF THE SHOWN AXIS FOR THE BATTERY CLAMP AND BRACKET BEFORE TIGHTENING THE RESPECTIVE BOLTS

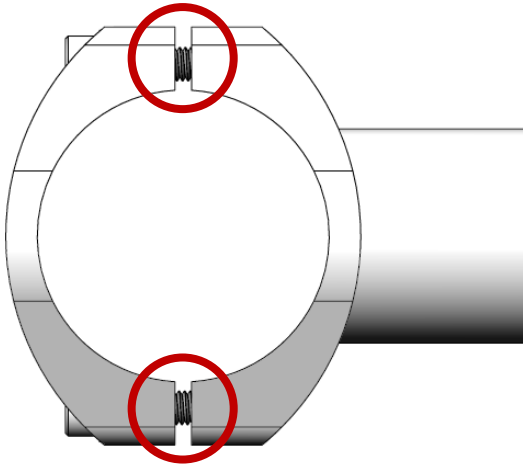

ENSURE EVEN GAP ON CLAMP WHEN TIGHTENING

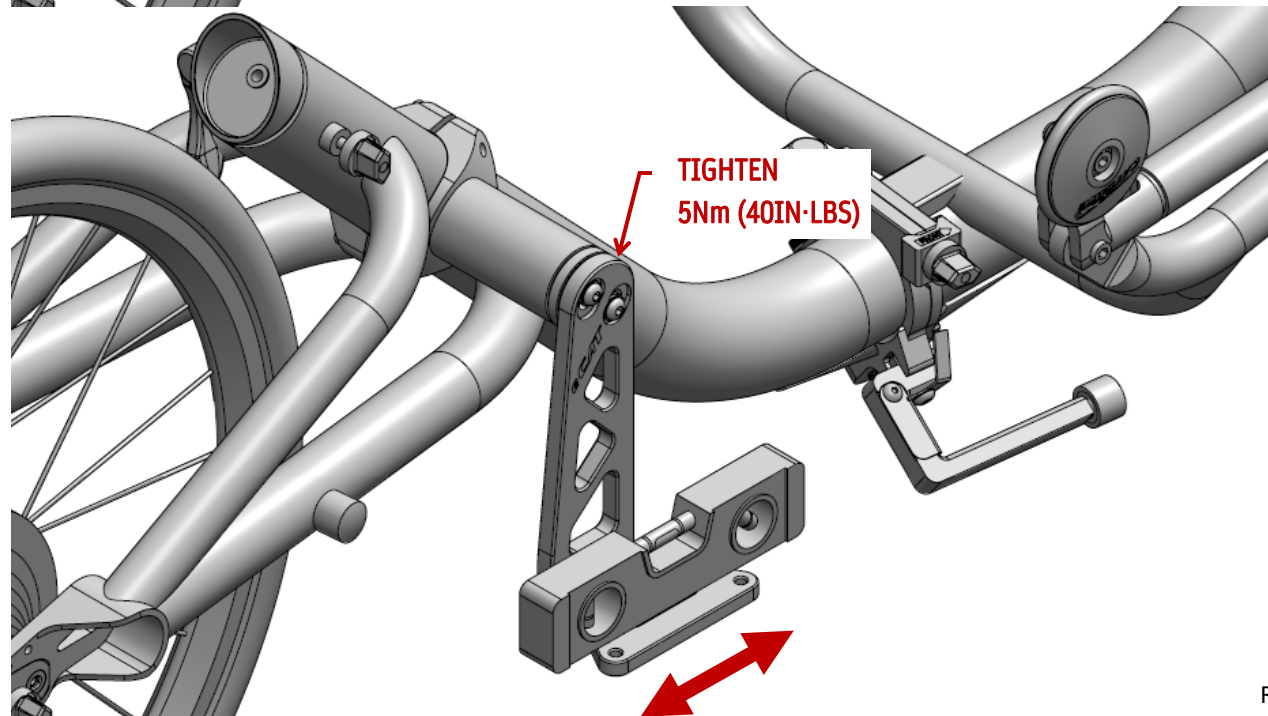
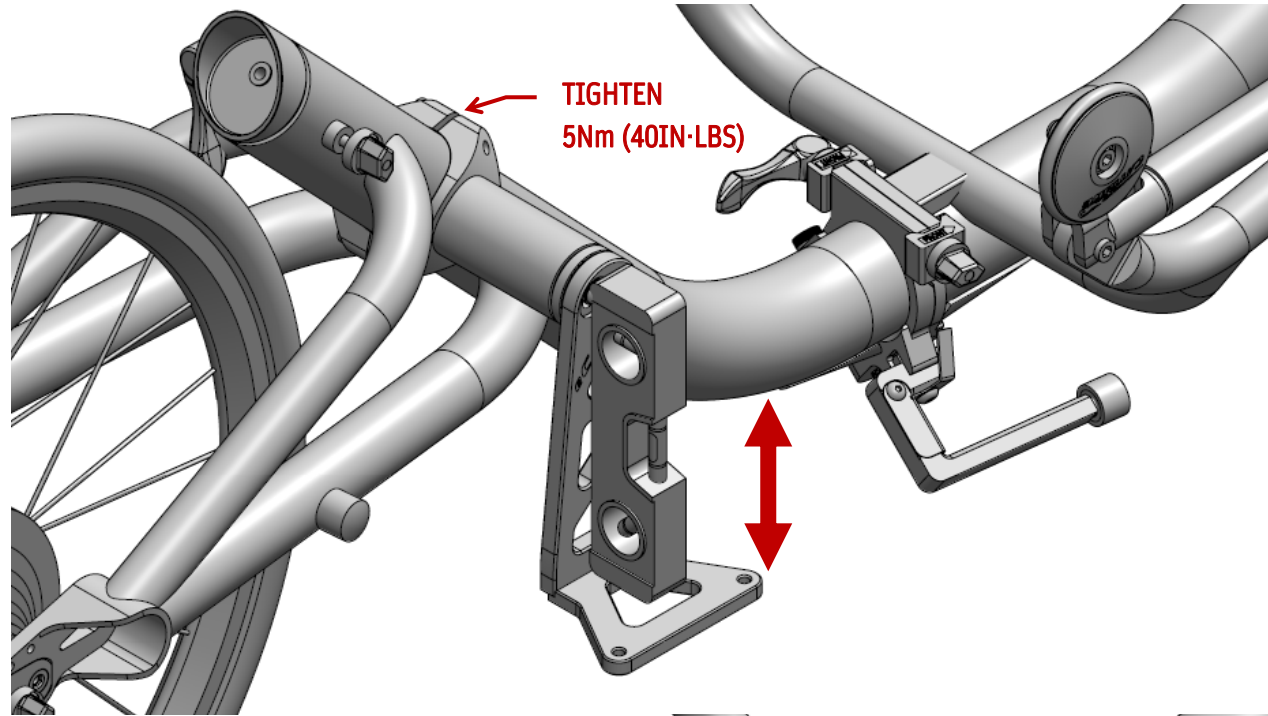

EKIT SPEED SENSOR ASSEMBLY

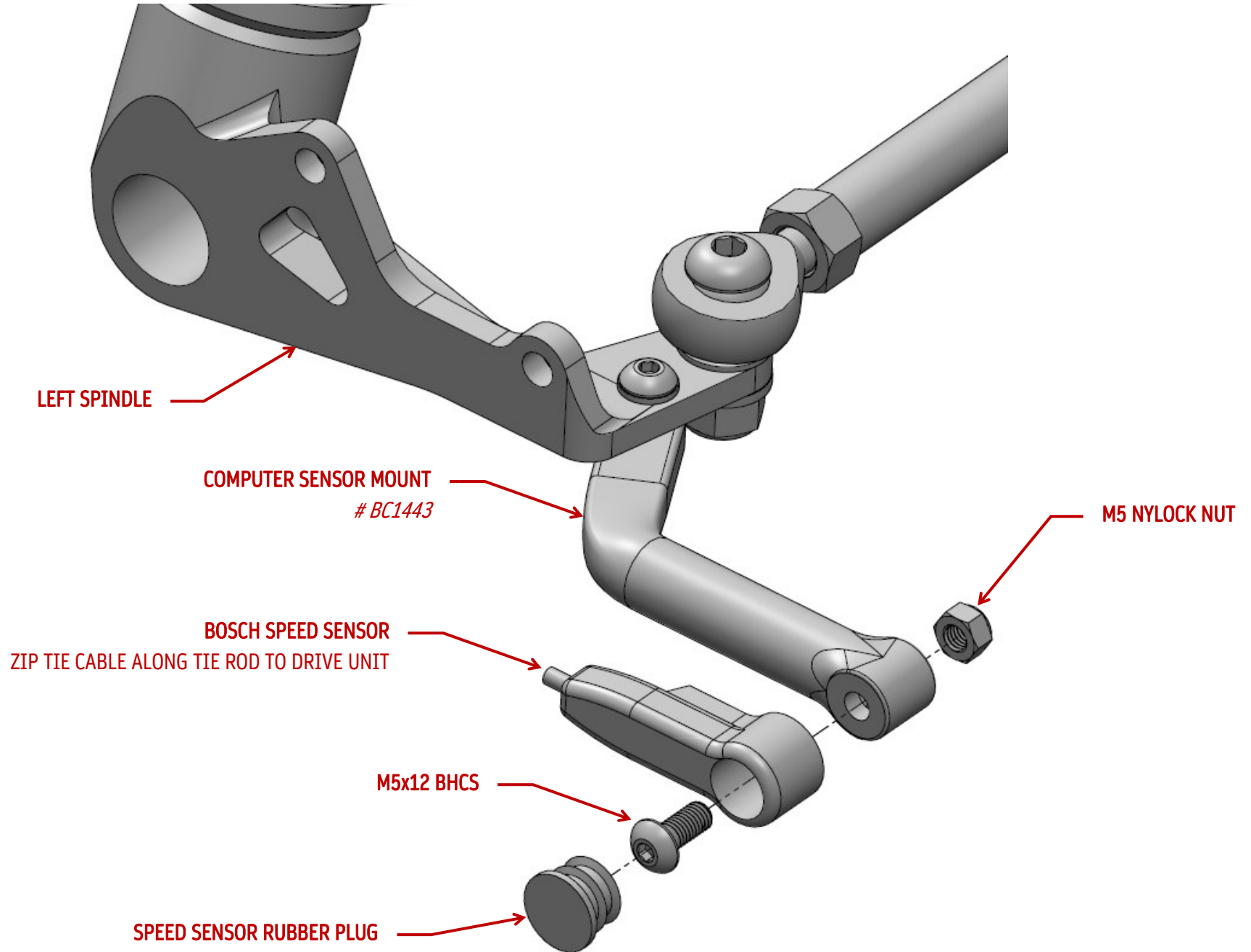

EKIT CONTROLLER ASSEMBLY

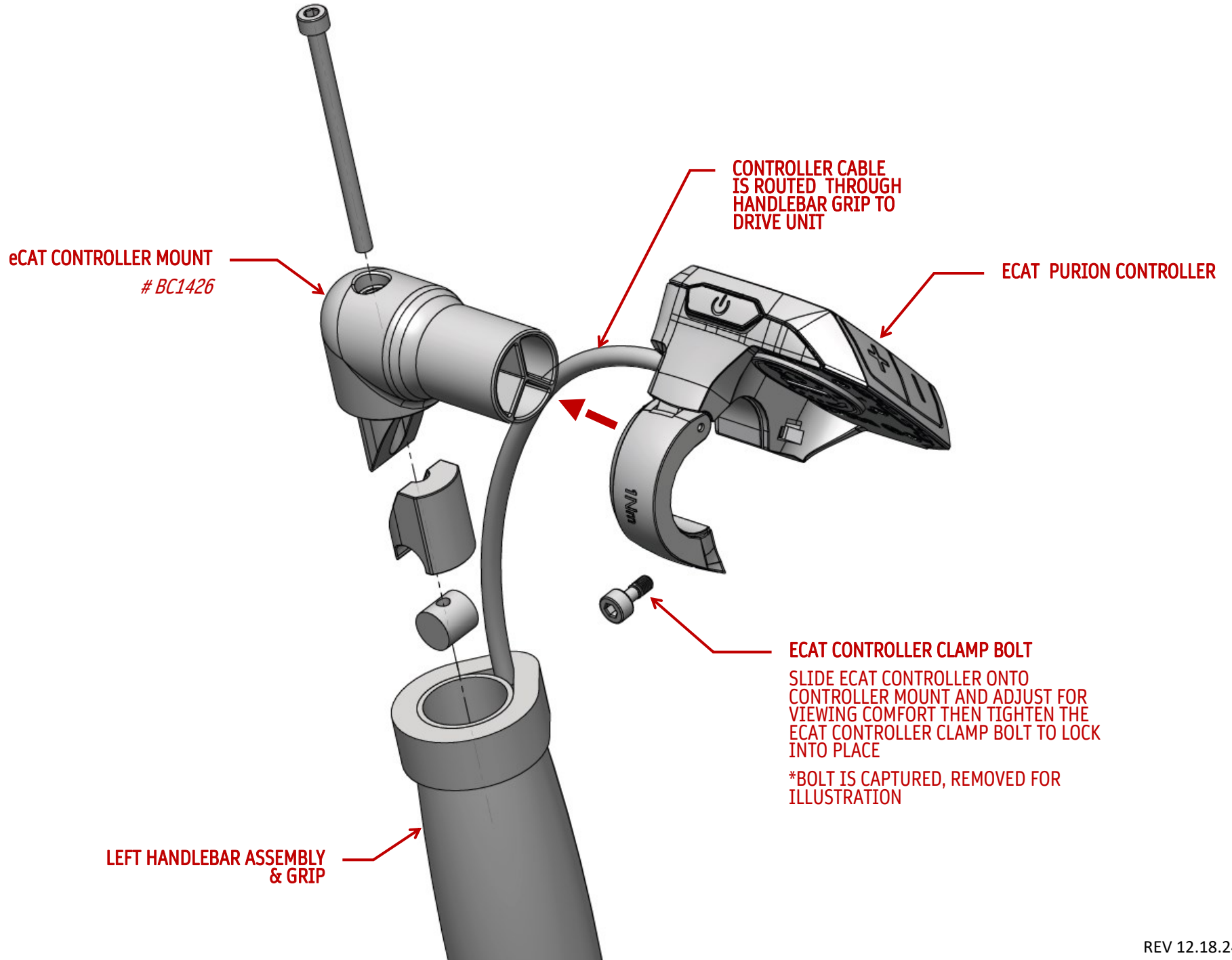

EKIT FRONT LIGHT ASSEMBLY

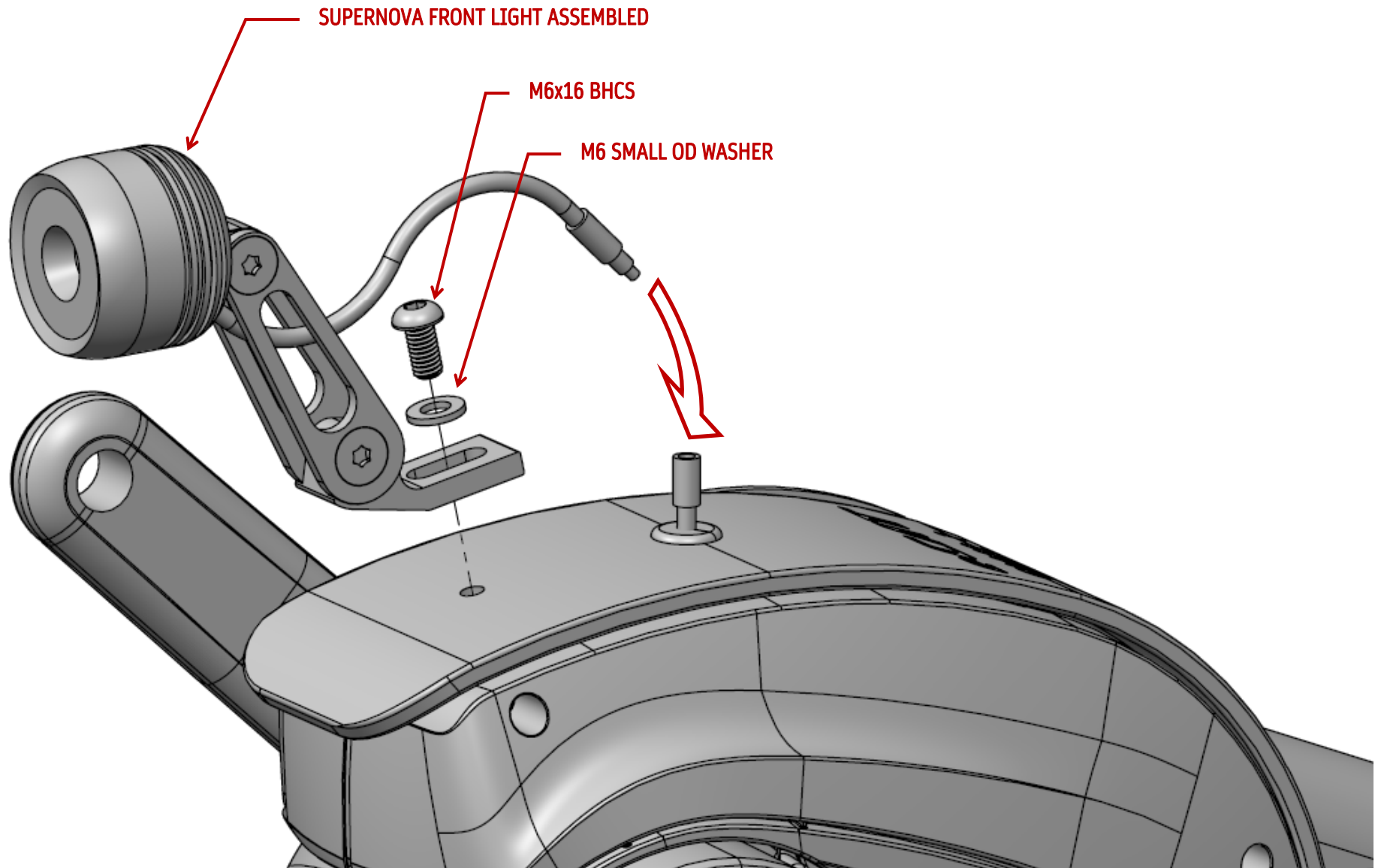

EKIT REAR LIGHT ASSEMBLY

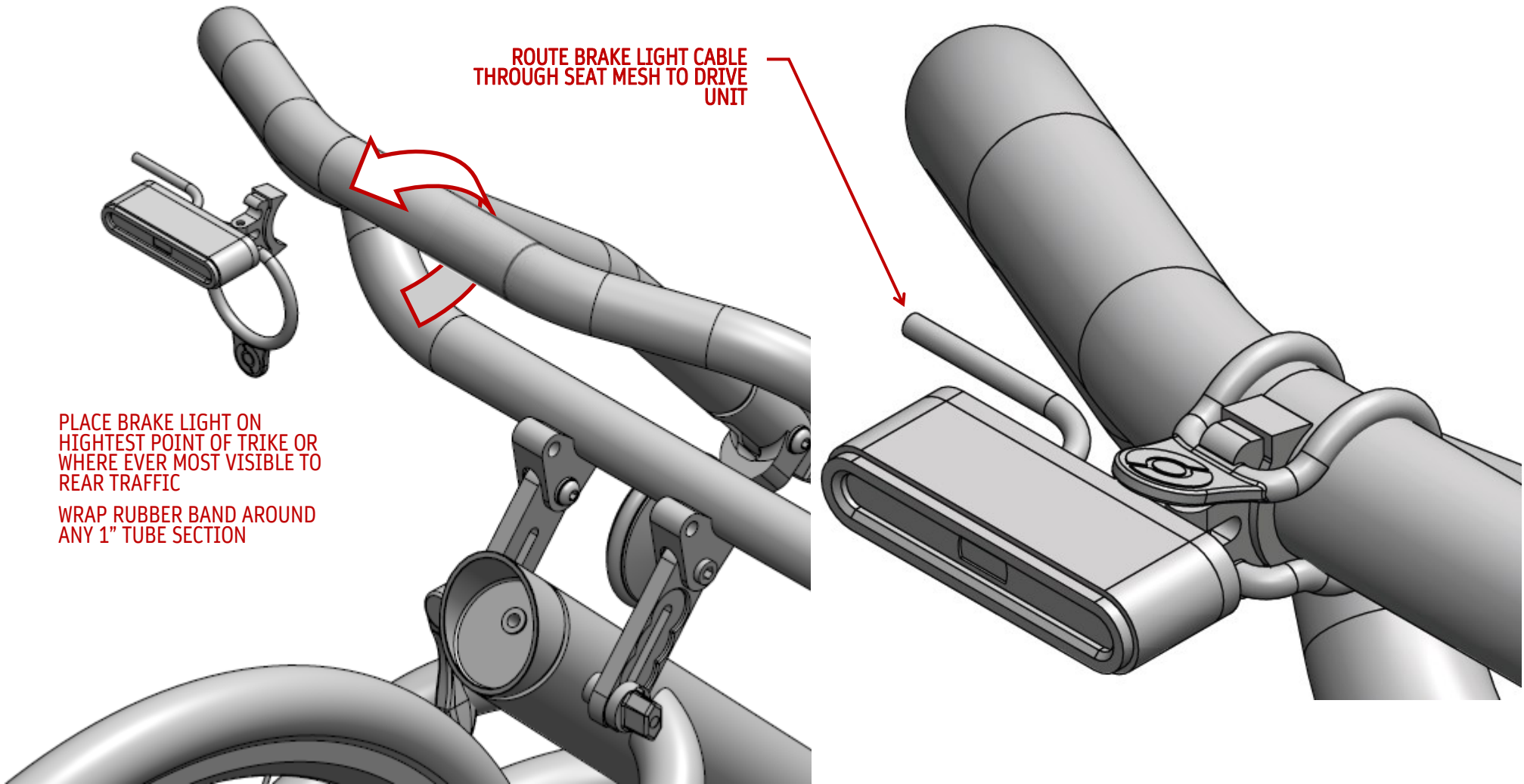

EKIT CABLE ROUTING

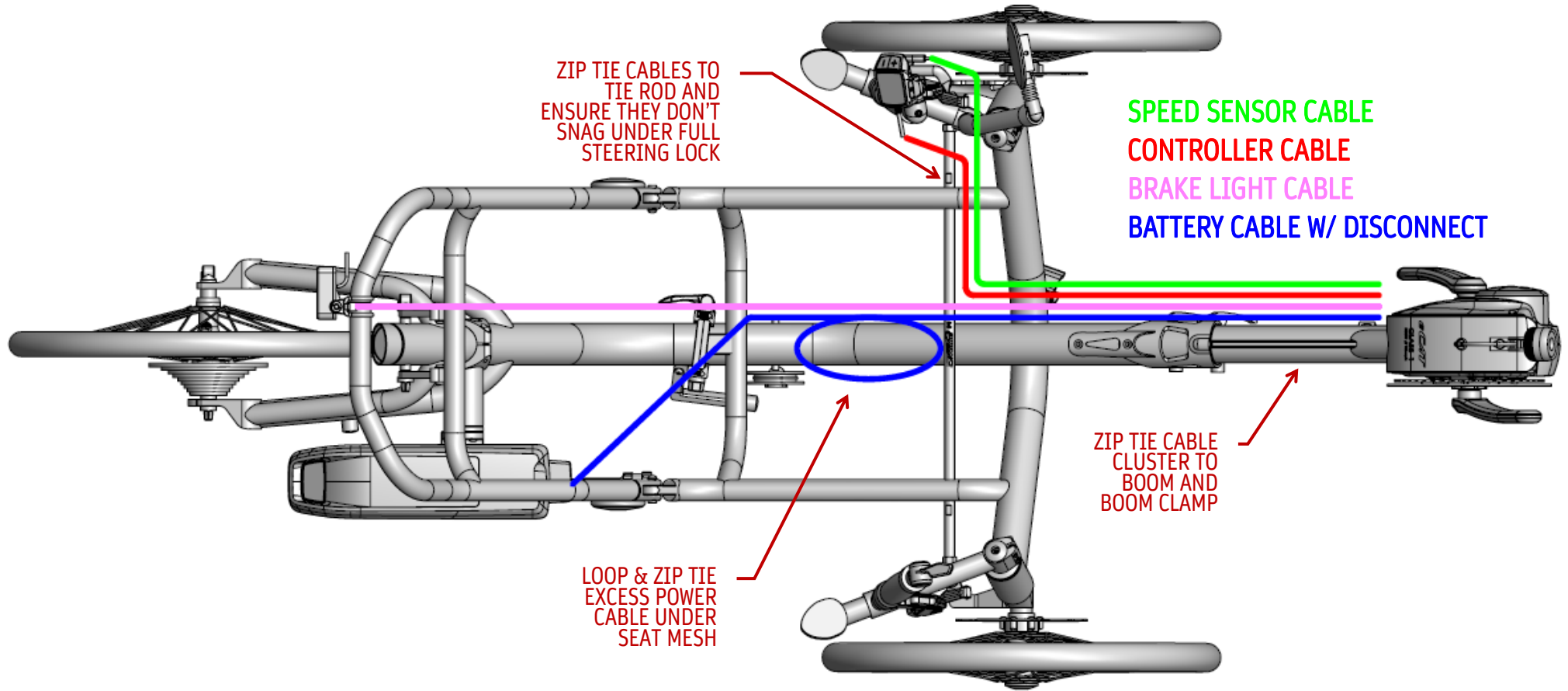

EKIT DISCONNECT BEFORE FOLDING

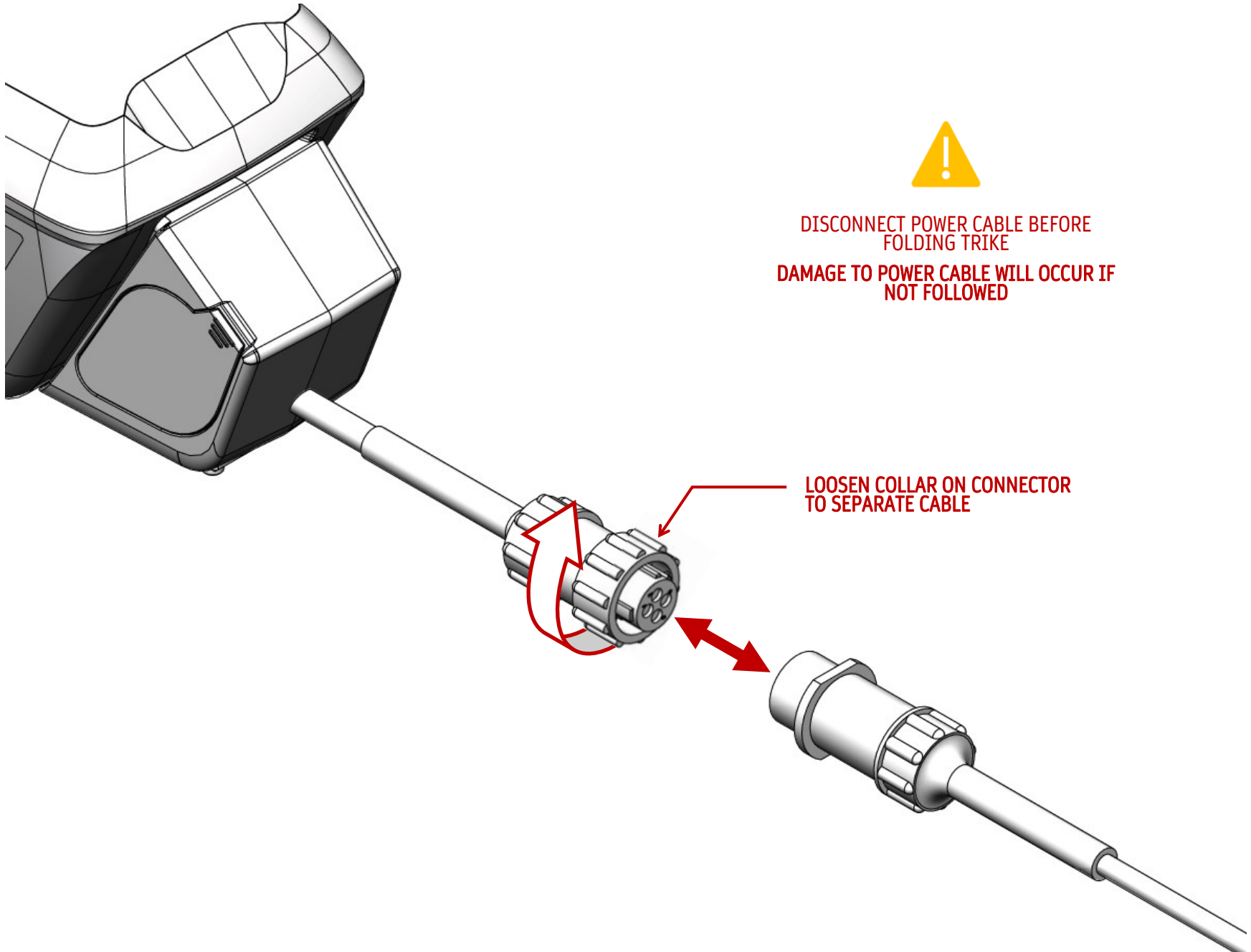

FENDER TO FRAME INSTALLATION

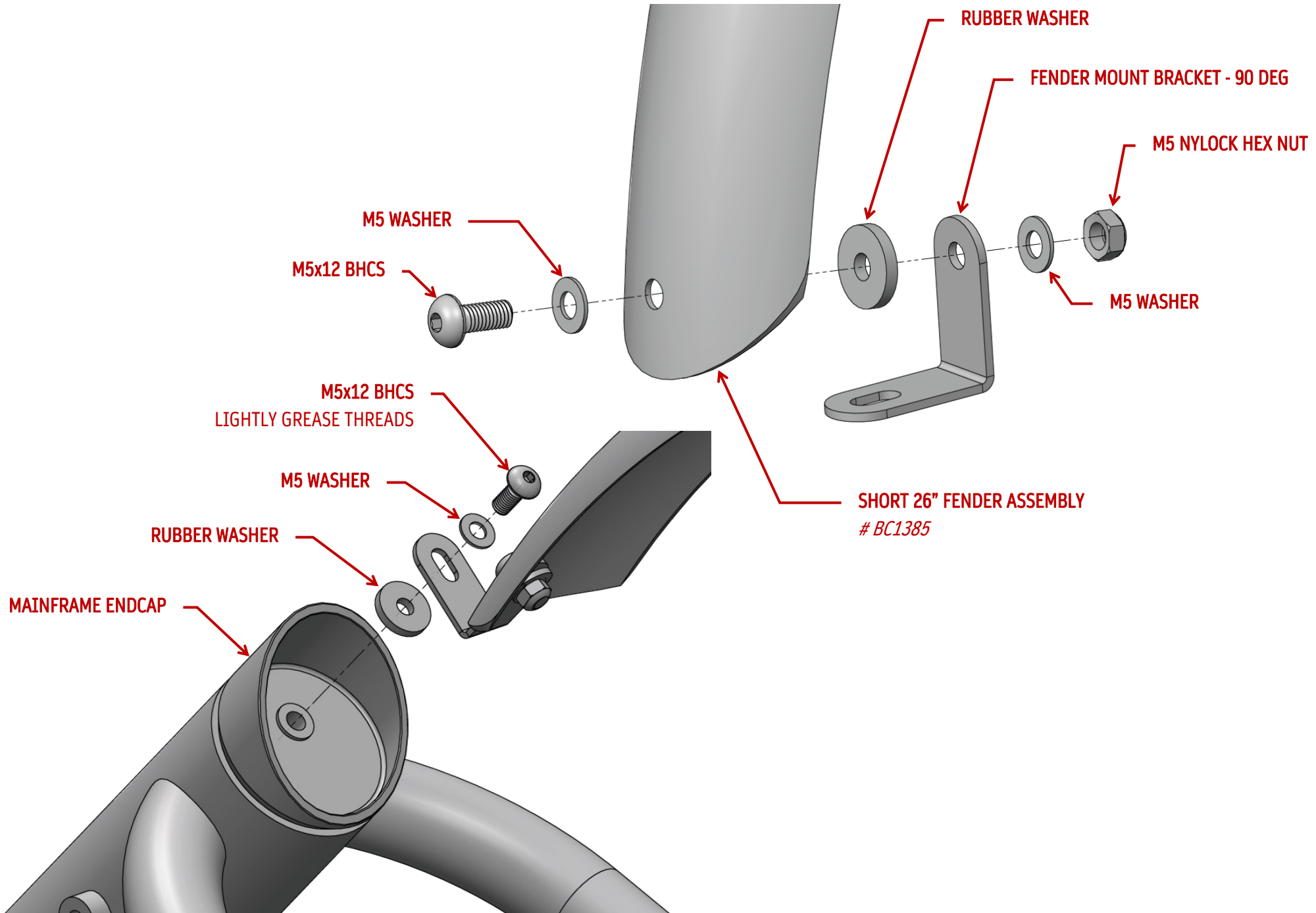

FENDER TO DROP OUT INSTALLATION

LEFT DROP OUT

RIGHT DROP OUT

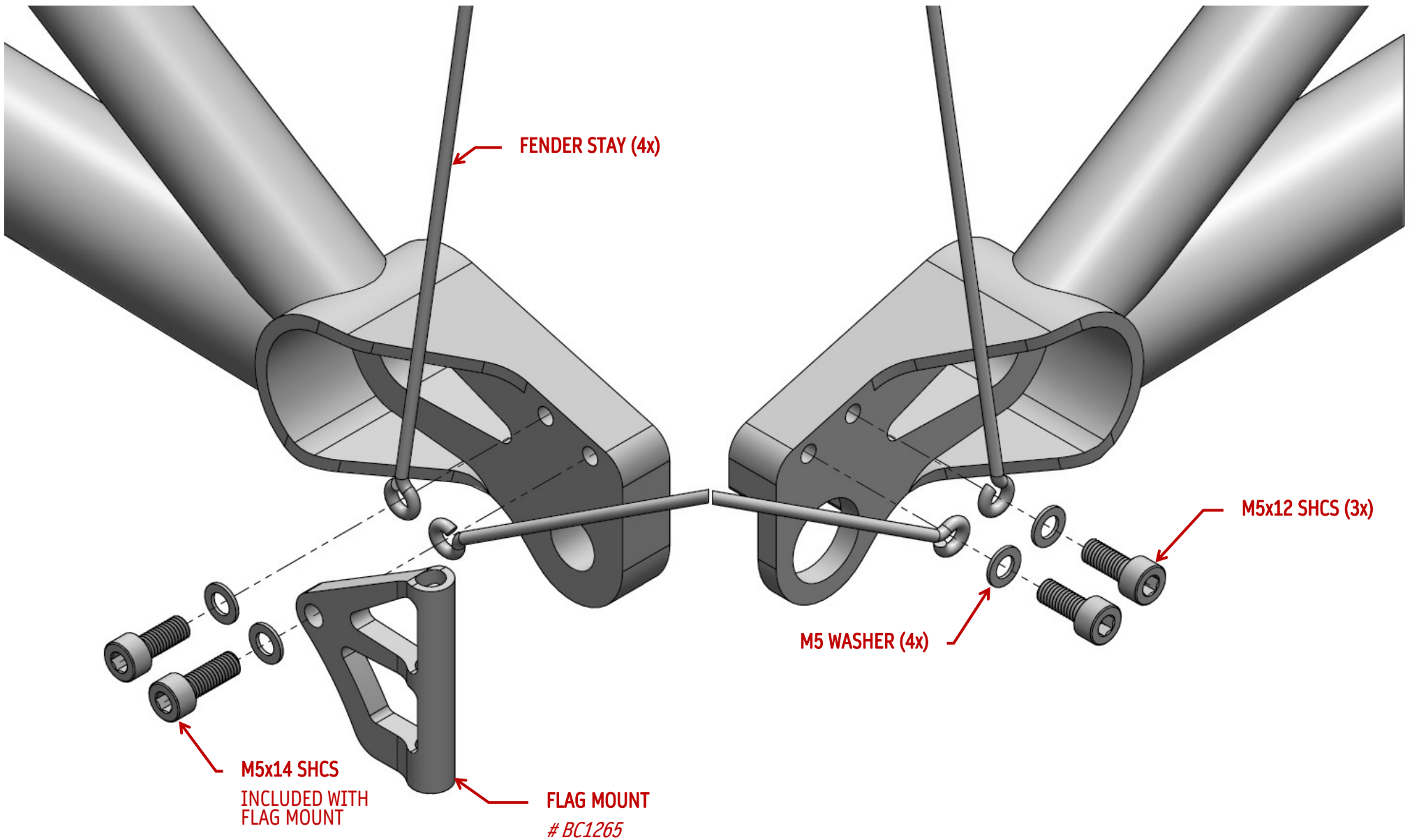

FENDER STAYS & FINAL INSTALLATION

